

ANSYS, Inc.
Southpointe
2600 ANSYS Drive
Canonsburg, PA U.S.A. 15317

Send address corrections to
AdvantageAddressChange@ansys.com

PERVASIVE ENGINEERING SIMULATION MEANS ROAD WORRIER NO MORE



You've got a lot riding on - and in - your autonomous vehicle. Safety is paramount and speed to market is critical. Only ANSYS can deliver a complete simulation solution for designing, testing and validating your autonomous vehicle.

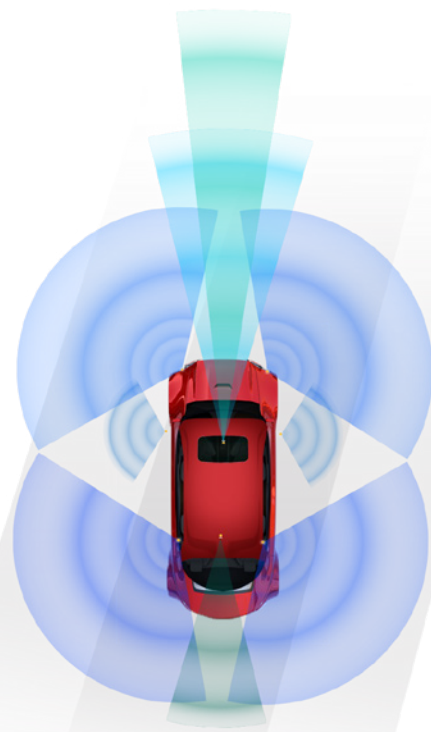

Learn more at [ansys.com/autonomous](https://www.ansys.com/autonomous)



ANSYS®

Excellence in Engineering Simulation

ADVANTAGE

ISSUE 2 | 2019

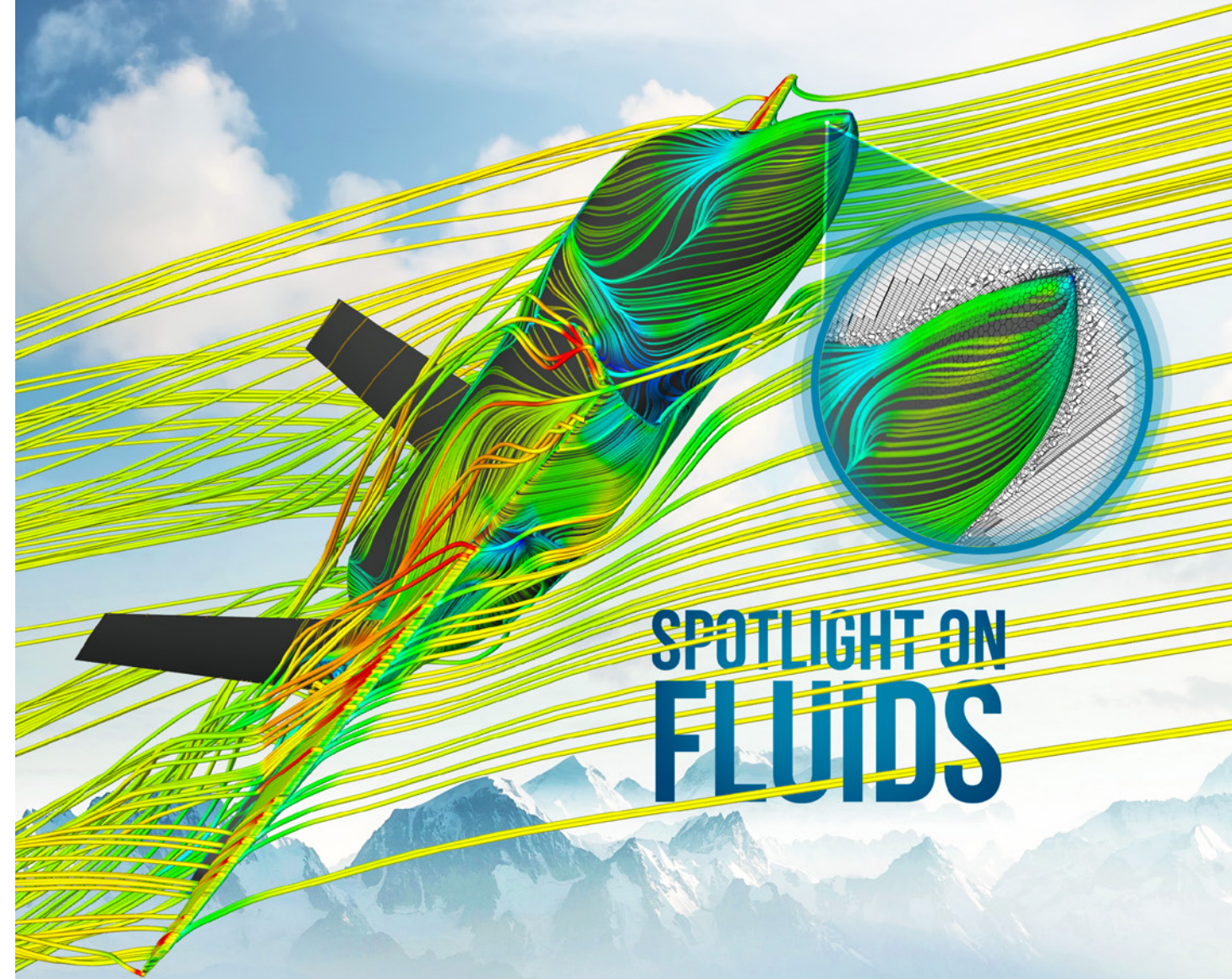

SPOTLIGHT ON FLUIDS

4
Get the Most Out
of ANSYS Fluent

8
Up to Speed with
Ferrari Competizioni GT

40
Smoother Transitions
with Mosaic Meshing

Flexible **Solutions** for the Engineering World

- Optimized compute platforms for CAE workloads
- Remote graphics and batch scheduling enabled
- Maximize efficiency of available licenses
- Simplified integration within existing infrastructures
- Built with the latest Intel® Xeon® Processors

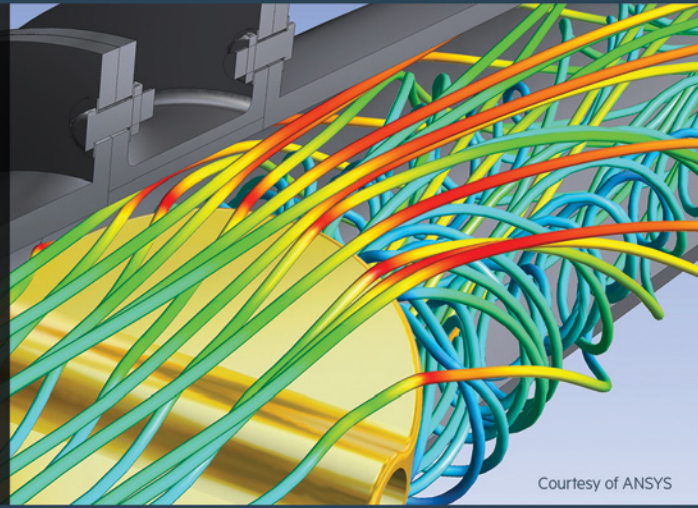

Courtesy of ANSYS

www.hpe.com/info/hpc-manufacturing-and-engineering

© Copyright 2019 Hewlett Packard Enterprise Development LP
© Copyright 2019 Intel, the Intel logo is trademark or registered trademark of Intel Corporation in the U.S. and/or other countries

Hewlett Packard
Enterprise



Extend HPC to the cloud

- Run ANSYS in globally available multi-cloud and hybrid cloud deployments
- Enterprise administration, governance and budgeting capabilities
- Integrated security meeting the strictest industry standards
- Access to virtually unlimited HPC resources interactively using a GUI on the master node

Sign up at:
<https://platform.rescale.com/ansys/signup/>

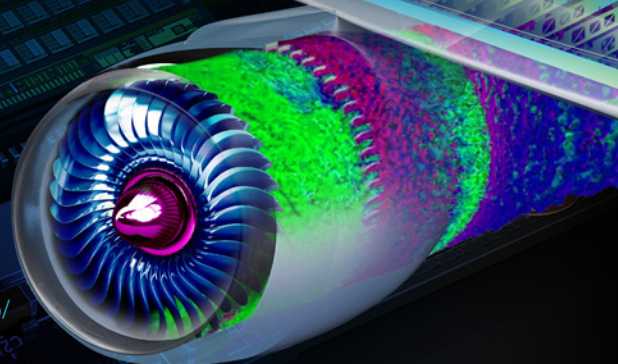

Improve Workflow, Improve Productivity

Intuitive workflow can make software tools more accessible, leading to increased productivity and profits. A clear simulation pathway from ideation to design to testing enables exploration of more designs in less time, so that every company can get products to market sooner at less cost.

Nobody likes a bottleneck in workflow. It slows down the entire process, even if all the other steps are optimized for maximum efficiency.

To leverage pervasive engineering simulation, every engineer in your organization must have access to simulation throughout design, testing and operation processes. To do this effectively means eliminating bottlenecks.

Recent advances in computational fluid dynamics have reduced these bottlenecks so engineers do not have to slow down at any point – from

software easy, even for engineers who only use simulation occasionally.

The meshing process is another point that slows the fluids simulation process. Meshing presents engineers with the challenge of dividing an intricately shaped geometrical model with complex boundaries into volumetric cells of different shapes that match perfectly with no gaps. Meshing can be time-consuming, sometimes involving manual cleanup of the geometry that requires valuable time from the engineer. Technology that conformally connects any type of



By **William Kulp**,
Lead Product Marketing Manager
Fluids
ANSYS

“Engineers can spend more time solving complex engineering problems and less time figuring out how to use the tools.”

forming the product idea to launching the product – whether they are recent graduates or world-class simulations experts.

MAKING FLUID SIMULATIONS MORE ACCESSIBLE FOR EVERY ENGINEER

One method of elevating the workflow is to make an already accessible software interface even more intuitive by incorporating a task-based workflow into the simulation setup process. A task-based workflow clearly presents the activities required for a specific simulation to the engineer so that the next logical step is always clear. This smooths the process for every engineer and ensures that they do not miss a critical step in the setup process. It also makes learning to use the

mesh to any other type of mesh, with no manual corrections needed, would make simulation setup easier and save time in the pre-processing phase and during the simulation run.

The latest version of ANSYS Fluent contains both advances. The new Fluent experience features a task-based workflow that leads engineers through the fluids simulation setup process step by step, ensuring that all necessary inputs are entered before the simulation run. The unique Mosaic meshing technology uses polyhedral mesh volumes to connect different

mesh types with no gaps. Mosaic automatically accelerates meshing while improving simulation accuracy.

With these two new features improving workflow, engineers can spend more time solving complex engineering problems and less time figuring out how to use the tools. Productivity will increase, and engineers can put their hard-earned knowledge to work on projects that challenge them to grow and to improve your product.

This issue of *ANSYS Advantage* describes Fluent's new task-based workflow and Mosaic meshing technology in detail, and presents examples of how organizations around the world and across many industries use ANSYS CFD solutions to solve some of the biggest challenges in fluid flow. We hope these examples will provide you with ideas to increase productivity and profitability. ▲



Introducing a New ANSYS Fluent Experience
ansys.com/new-experience

Table of Contents

SPOTLIGHT ON FLUIDS

4

BEST PRACTICES

GET THE MOST OUT OF THE ANSYS FLUENT TASK-BASED WORKFLOW

Following some easy best practices within the workflow can make using ANSYS Fluent even smoother for both experts and novices.

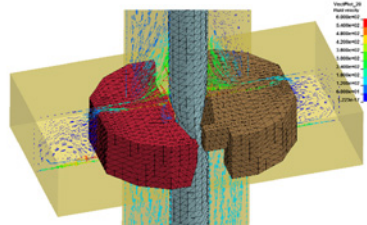

16

OIL AND GAS

WHEN THE PRESSURE IS ON: PREVENTING WELL BLOWOUTS

Researchers determined what stopped blowout preventers from deploying during an offshore well catastrophe.

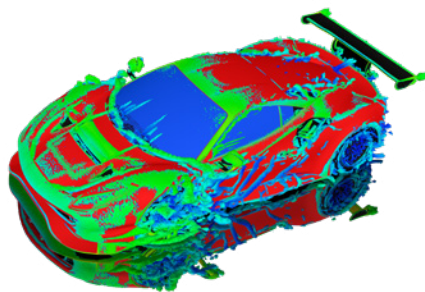

8

AUTOMOTIVE

UP TO SPEED

Ferrari Competizioni GT leverages next-level, automated meshing capabilities from ANSYS to increase its simulation productivity by 300% — placing new designs on the track in a fraction of the time required previously.

12

INDUSTRIAL EQUIPMENT

A BREAKTHROUGH IN AIR-COOLED STEAM CONDENSERS

EVAPCO, Inc., developed an entirely new heat exchanger configuration that maximizes heat transfer, minimizes pressure drop, and constrains energy consumption and costs.

20

ENERGY

GENERATING HYDROGEN FOR ENERGY STORAGE

ANSYS CFD aids engineers in developing an energy storage solution using hydrogen.

ABOUT THE COVER

With the new ANSYS Fluent experience engineers can speed computational fluid dynamics simulation using a task-based workflow and Mosaic-enabled meshing. Learn more on page 4.

Geometry for cover image courtesy Mehmet Mamuşoğlu through GrabCAD. Simulation performed by John Stokes.

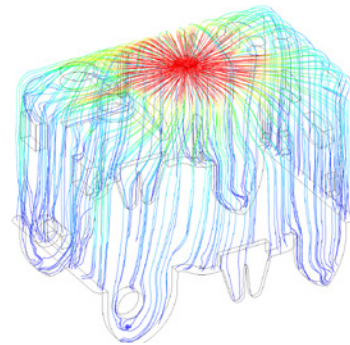

24

COMBUSTION

REWRITING THE FORMULA FOR FIREWORKS

By leveraging simulation to reduce the amount of smoke, fireworks displays can be brighter and more dynamic.

27

MANUFACTURING

CFD FOR INJECTION MOLDING

Schneider Electric engineers validated the use of ANSYS CFD software for mold-filling simulation.

30

CONSUMER GOODS

FLUSH WITH INNOVATION

A global leader in bathroom products relies on engineering simulation to reduce time and costs in product development.

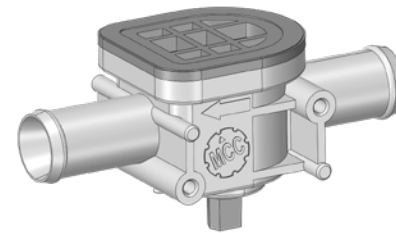

33

HEAVY EQUIPMENT

HEATING UP OFF-ROAD VEHICLE CABINS

Engineers help improve cabin comfort for off-road vehicle operators by leveraging CFD.

36

ENERGY

ENERGIZING GENERATOR DESIGNS

Leveraging ANSYS simulation and an improved workflow, INDAR engineers improve generator design accuracy and accelerate all stages of their simulation.

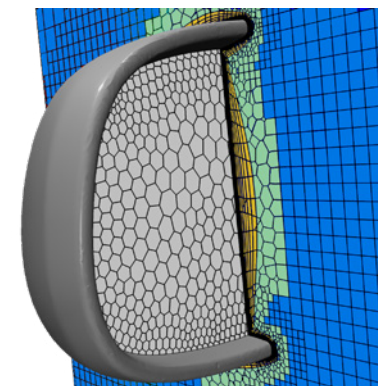

40

SOLUTIONS

SMOOTHER TRANSITIONS WITH MOSAIC MESHING

ANSYS Mosaic meshing technology results in faster simulations with greater solution accuracy while using less RAM.

SIMULATION@WORK

43

SEMICONDUCTORS

EARLY SIMULATION AVOIDS CHIP BURN

Qualcomm engineers were able to identify and fix redundant switching in their GPU to improve the power efficiency of key design blocks by 10%.

DEPARTMENTS

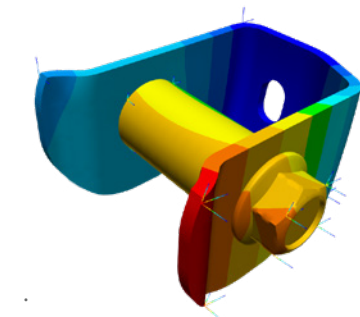

47

SOLUTIONS

POWERING THE CLOUD-BASED HPC REVOLUTION

ANSYS Cloud allows engineers to model and develop their products faster than ever and to expedite the path to market.

51

ACADEMIC

DEVELOPING THE NEXT GENERATION OF AUTOMOTIVE ENGINEERS

The University of Applied Sciences at Kempton is helping to develop the disruptive automotive technologies of tomorrow and the engineers who will deliver them.

55

NEWS

SIMULATION IN THE NEWS

A roundup of news items featuring simulation

Welcome to *ANSYS Advantage!* We hope you enjoy this issue containing articles by ANSYS customers, staff and partners.

The Editorial Staff, ANSYS Advantage
ansys-advantage@ansys.com

Executive & Managing Editor
Chris Reeves

Editorial Advisers
Amy Pietzak, Tom Smithyman

Editorial Contributor
ANSYS Customer Excellence
North America

Senior Editor
Tim Palucka

Editors
Erik Ferguson Walter Scott
Kara Gremillion Terri Sota
Mark Ravenstahl Scott Nyberg

Art Director **Designer**
Ron Santillo Dan Hart Design

ANSYS, Inc.
Southpointe
2600 ANSYS Drive
Canonsburg, PA
15317
USA

Subscribe at ansys.com/magazine

Realize Your Product Promise®

If you've ever seen a rocket launch, flown on an airplane, driven a car, used a computer, touched a mobile device, crossed a bridge, or put on wearable technology, chances are you've used a product where ANSYS software played a critical role in its creation.

ANSYS is the global leader in engineering simulation. We help the world's most innovative companies deliver radically better products to their customers. By offering the best and broadest portfolio of engineering simulation software, we help them solve the most complex design challenges and engineer products limited only by imagination.

Neither ANSYS, Inc. nor Dan Hart Design guarantees or warrants accuracy or completeness of the material contained in this publication.

ACT, Additive Print, Additive Science, Additive Suite, AIM, Aqwa, Autodyn, BladeModeler, CFD, CFD Enterprise, CFD Flo, CFD Premium, CFX, Chemkin-Pro, Cloud Gateway, Customization Suite, DesignerRE, DesignerSI, DesignModeler, DesignSpace, DesignXplorer, Discovery Live, EKM, Electronics Desktop, Elastic Licensing, Enterprise Cloud, Engineering Knowledge Manager, EnSight, Explicit STR, Fatigue, FENSAP-ICE, FENSAP-ICE-TURBO, Fluent, Forte, Full-Wave SPICE, HFSS, High Performance Computing, HPC, HPC Parametric Pack, Icepak, Maxwell, Mechanical, Mechanical Enterprise, Mechanical Premium, Mechanical Pro, Meshing, Multiphysics, Nexxim, OptiMetrics, OptiSLang, ParICs, PathFinder, Path FX, Pervasive Engineering Simulation, PExprt, Polyflow, PowerArtist, Q3D Extractor, RedHawk, RedHawk-SC, RedHawk-CTA, Rigid Body Dynamics, RMXprt, SCADE Architect, SCADE Display, SCADE LifeCycle, SCADE Suite, SCADE Test, SeaHawk, SeaScape, SImwave, SImplorer, Solver on Demand, SpaceClaim, SpaceClaim Direct Modeler, Structural, TGrid, Totem, TPA, TurboGrid, Twin Builder, Workbench, Vista TE, Realize Your Product Promise, Sentinel, Simulation-Driven Product Development

ICEM CFD is a trademark licensed by ANSYS, Inc. LS-DYNA is a registered trademark of Livermore Software Technology Corporation. nCode DesignLife is a trademark of HBM nCode. All other brand, product, service, and feature names or trademarks are the property of their respective owners.



Get the Most Out of the ANSYS Fluent Task-Based Workflow

“Expand the *workflow* by creating custom journals that can perform *advanced Fluent* operations tailored to a specific organization.”

Creating a watertight geometry workflow for the pre-processing step of computational fluid dynamics (CFD) simulation is now easier than ever with the new ANSYS Fluent experience. You can access the workflow from the single-window Fluent interface or directly from ANSYS Workbench.

Employing a relatively complicated model as an example — air cooling of an electrical motor — unveils nine best practices to simplify the process even further.

TIP 1: FAULT-TOLERANT WORKFLOW FOR NON-WATERTIGHT GEOMETRIES

A fault-tolerant workflow is available to place a “wrapper” — a layer of mesh that covers up surface imperfections in the geometry — around non-watertight (“dirty”) geometries. This can be especially helpful in simulations of the external aerodynamics of a car, for instance, where there is too much detail to spend the time manually closing leaks in the geometry. This saves time while sacrificing only a little in simulation accuracy.

TIP 2: CREATE AN OUTER FLOW BOUNDARY USING SHARE TOPOLOGY

For external flow simulations, like the air flow cooling a motor, create an outer flow boundary in ANSYS SpaceClaim by drawing a cube around the motor and using the Share Topology function.

Share Topology combines all overlapping faces between two solids into one face. It also resolves the intersection between the cube and any part of the motor. The flow volume is extracted as part of the Surface Mesh operation in Fluent. The volume takes the shape of the void between the boundaries of the cube and the motor.

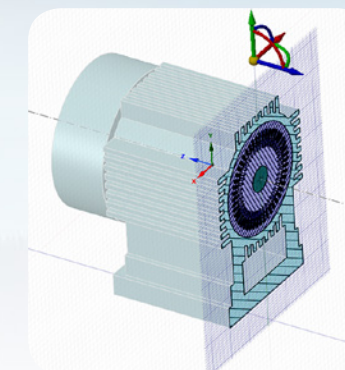

Share Topology defines a flow region without Boolean operations.

TIP 3: NAME THE ENTITIES IN ANSYS SPACECLAIM

In the geometry in SpaceClaim, include “fluid” in the name of the cube around the motor geometry. This automatically identifies it as a fluid region within the watertight geometry workflow. And, by adding descriptive strings to the names of other entities, like inlets, outlets and symmetry planes, it is easier for ANSYS Fluent to track them in the pre-processing stage and during simulation.

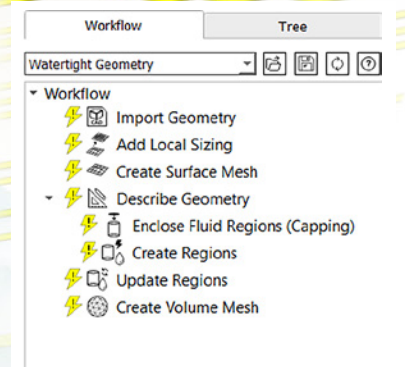

The watertight workflow tree

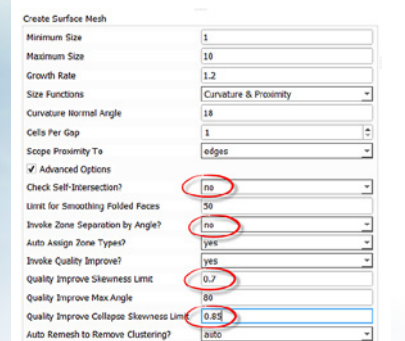

Advanced options to speed up meshing

The new ANSYS Fluent experience enables engineers to perform computational fluid dynamics simulation using a task-based workflow. This ensures that anyone can take the right steps to set up a CFD simulation. Following some easy best practices within the workflow can make using ANSYS Fluent even smoother for both experts and novices.

By Erling Eklund, Lead Software Developer, ANSYS

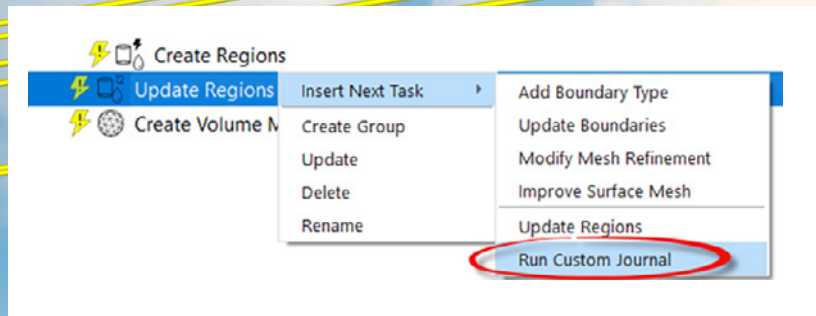

Running custom tasks in the workflow

TIP 4: USE NATIVE FLUENT FILES

When importing the CAD model into the Fluent task-based workflow, the software creates a native version of that file with a .pmdb extension. The next time the same model is imported, reading in the .pmdb file retrieves the geometry much faster than returning to the original CAD geometry.

Another advantage of working with the .pmdb file is that it is operating-system-independent, so working in Linux is possible if desired.

TIP 5: SPEED UP SURFACE MESHING OF CFD GEOMETRY

Some surface mesh options can be toggled to make the meshing process faster. By labeling all entities — like “inlet” or “fluid” — in SpaceClaim (see Tip 2), the need to use zone separation to determine regions within the Surface Mesh is eliminated.

“Creating a mesh that is ready for *CFD analysis* now takes minutes when it used to take hours.”

Also, turn off Check Self-Intersection. This operation checks the model for any overlapping faces. It is no longer needed thanks to the Share Topology function.

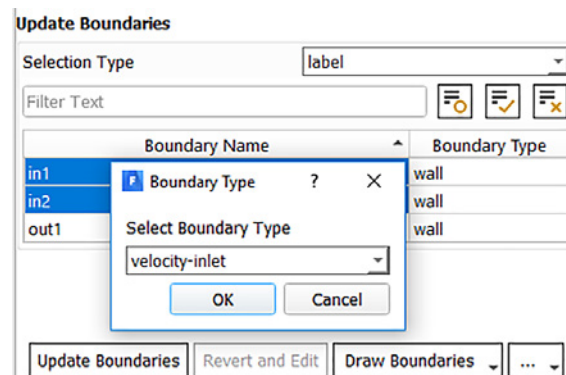

Click Update after changing the name or type of a zone when verifying the geometry.

TIP 6: VERIFY CFD GEOMETRY FOR ANSYS FLUENT

During the surface meshing operation, Fluent defines boundary types to zones, and region types to volumes. These definitions are based on the entity names specified in SpaceClaim. For example, a boundary named “gas-inlet” is assigned a “velocity-inlet” boundary type.

As a best practice, verify that the boundary and region types are assigned properly before volume meshing. Change a boundary or region’s name and type as needed. Selecting multiple names and right-clicking changes multiple boundaries or regions into the same type. Just remember to click Update once all the boundary types are verified.

TIP 7: USE MOSAIC FOR CONFORMAL VOLUME MESHING

When the volume meshing starts, Fluent makes a fine mesh at the boundary layers. However, maintaining a fine mesh throughout the bulk would be computationally expensive. Use Mosaic meshing technology to link optimal mesh types in the bulk and on the boundary.

First, add boundary layers in the Create Volume Mesh panel. These will only be added on fluid region walls. Then, access the full suite

“Easy access to *parallel processing* speeds up Mosaic poly-hexcore *mesh generation* by up to a factor of 10.”

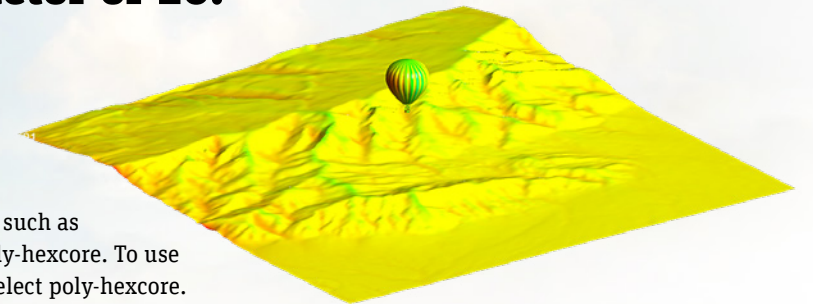

of conformal volume meshing methods, such as tetrahedral, hexcore, polyhedral and poly-hexcore. To use the latest Mosaic meshing technology, select poly-hexcore.

At this point, the standard watertight geometry workflow is complete, and the model can be meshed. It is still possible to insert additional tasks into the task-based workflow if they are needed, like further refining the volume mesh. Tweaking some standard variables can control the mesh quality.

Expand the standard watertight geometry workflow by creating custom journals. These customized tasks perform advanced Fluent operations that are tailored to a specific organization. Contact ANSYS support to get the user commands needed to set up a custom journal.

TIP 8: SPEED MESH GENERATION WITH PARALLEL PROCESSING

Use parallel processing to speed up Mosaic poly-hexcore mesh generation by up to 10 times. Utilize up to 64 cores on either your laptop or a cluster, with no need for an HPC license.

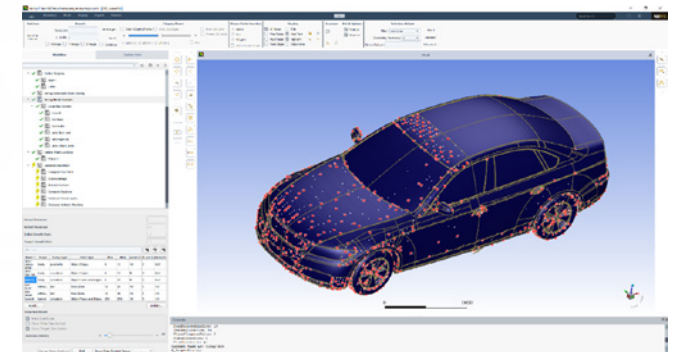

TIP 9: EDIT AND SHARE THE MESHING WORKFLOW AT ANY TIME

Some of the biggest benefits of the watertight geometry workflow are the ability to save it, return to it and edit it at any point. Changing a task early in the task-based workflow is easy — even during the final stages of meshing the geometry.

When the workflow is satisfactory, save it and share it with team members. Use the task-based workflow for similar models to give team members a head start on meshing the next design iteration of the motor or other product.

The watertight geometry workflow can also be built into a script that runs the mesh through the Fluent solver. To create this script, use the Start Journal function. Fluent records the script as the workflow proceeds.

The new watertight geometry workflow is a significant timesaver. Creating a mesh that is ready for CFD analysis now takes minutes when it used to take hours.

SAVE VALUABLE TIME

These best practices free up valuable time to work on solving engineering challenges rather than setting up the simulation tools to do so. Give them a try on a future fluids simulation project. ⚠️

Fault-tolerant workflow uses a wrapper to speed meshing for non-watertight geometries
Geometry courtesy Technical University of Munich

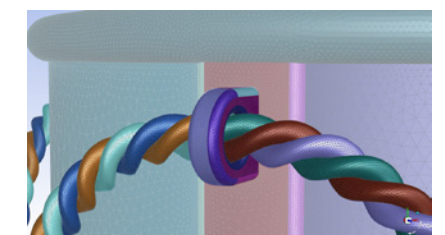

UP to Speed

By **Ferdinando Cannizzo**
Ferrari Competizioni GT
Head of GT Racing Car
Development
Maranello, Italy

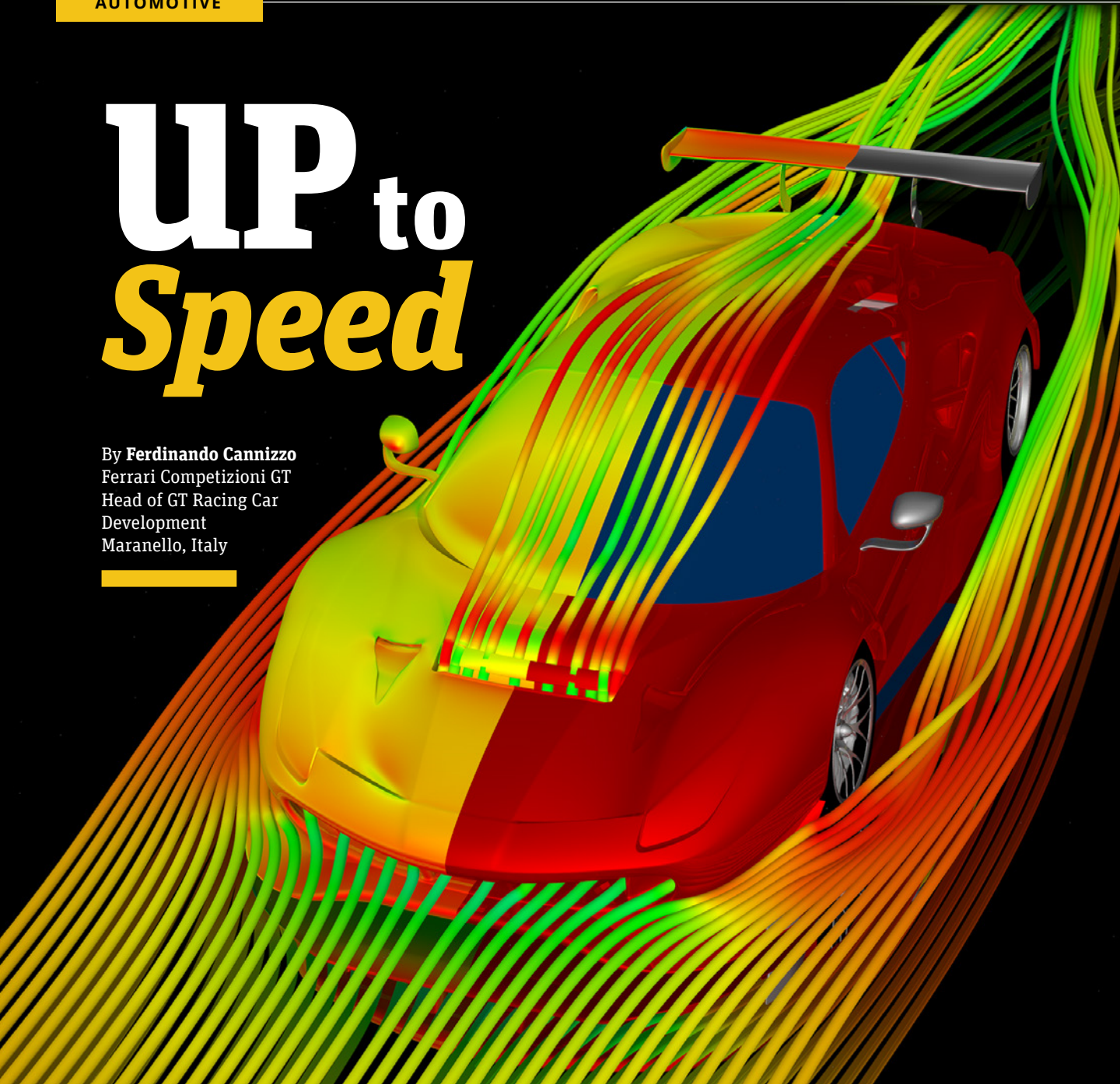

A longtime user of engineering simulation, Ferrari Competizioni GT leverages next-level, automated meshing capabilities from ANSYS to increase its simulation productivity by 300% — placing new designs on the track in a fraction of the time required previously. The Ferrari

name is known around the world for speed, high quality and precise engineering, and its GT race cars both reflect and reinforce the company's automotive leadership.

Known for its luxury sports cars — which have become an automotive industry standard for speed and performance — Ferrari is also known for its success in Gran Turismo, or GT, racing. Each year, the Ferrari Competizioni GT racing organization competes in about 25 international events, battling teams from around the world.

Ferrari engineers work constantly to optimize aerodynamics and other aspects of vehicle designs, with the goal of crossing the finish line first and reinforcing Ferrari's brand leadership.

Every two or three years, the Ferrari Competizioni GT engineering team pushes itself to engineer an upgraded GT race car within a 12-month window. These changes must not only improve performance but must reflect new industry standards introduced by the Fédération Internationale de l'Automobile (FIA).

“Ferrari engineers can run three times as many CFD simulations in the same amount of time — and develop cars faster than ever before.”

SETTING THE PACE

To meet this aggressive schedule and succeed in this intensely competitive environment, Ferrari identifies and applies the most innovative engineering technologies available. Since 1998, the team has partnered with ANSYS to ensure that it is constantly adopting the most advanced simulation capabilities, as well as best-in-class engineering simulation practices.

For years, Ferrari Competizioni GT has leveraged the power and scope of ANSYS Fluent computational fluid dynamics (CFD) software to optimize the aerodynamics of its race cars. Supplementing physical wind-tunnel testing — which is time- and cost-intensive — with CFD simulations in a virtual world has yielded significant benefits for Ferrari. Engineers can generate a fully realized, virtual 3D vehicle design much faster than building a physical prototype — then test a large population of geometrical variations to assess their effects on the model's aerodynamic performance. This allows Ferrari's product development team to build expensive, scaled-down prototypes of only the most promising designs to validate with physical wind-tunnel testing.

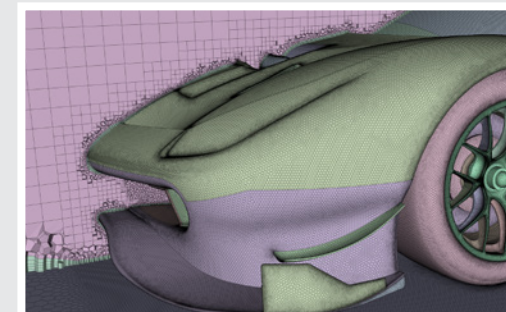

By creating a finely detailed mesh of the race car's chassis, the Ferrari GT engineering team can simulate and optimize the effects of air and other physical forces that will impact the vehicle's performance under real-world racing conditions.

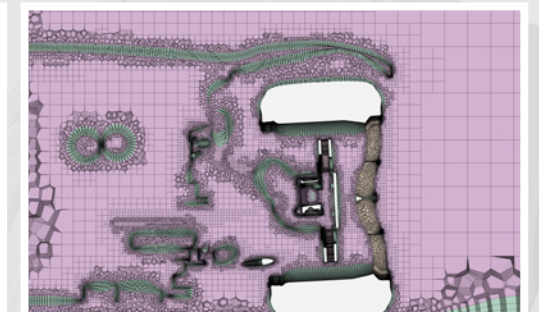

Fluent's task-based workflows speed the creation of a high-quality Mosaic-enabled mesh for complicated geometries such as the underside of this Ferrari GT car.

This process has proven highly successful, cutting time and costs from the overall design cycle for a new race car. In addition, Ferrari has been impressed with the power and fidelity of ANSYS Fluent, particularly in modeling highly complex physical phenomena such as turbulence. The CFD simulation results have predicted the wind-tunnel tests with a very high degree of accuracy.

Recently, Ferrari Competizioni GT reached an agreement with ANSYS that has given its engineering team access to a groundbreaking new simulation capability in ANSYS Fluent: Mosaic-enabled poly-hexcore meshing.

BREAKING AWAY FROM THE PACK

In the past, Ferrari engineers used ANSYS Fluent to generate a finely detailed mesh around the race car, which enabled flow simulations at a very high degree of accuracy. However, creating this fine mesh and running CFD simulations on it required a high level of expertise and

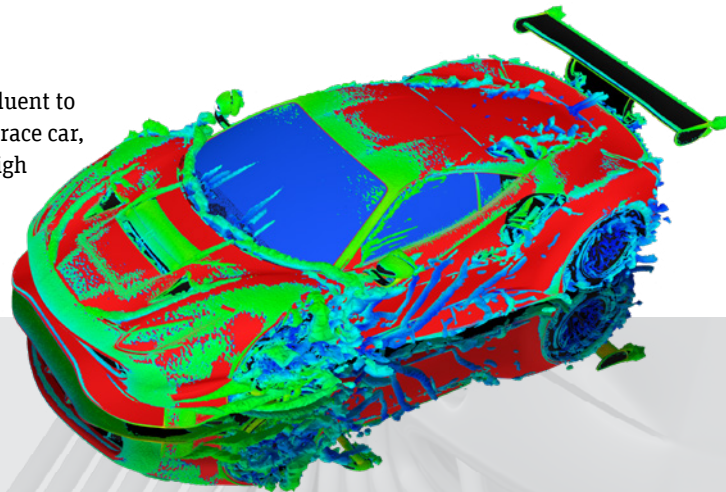

ANSYS Fluent simulation results show flow vortices created by the sharp corners and body details of a Ferrari GT race car.

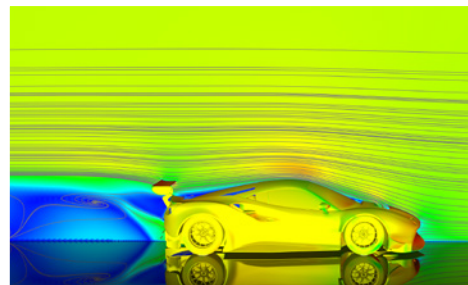

ANSYS Fluent simulation showing pressure contours and air velocity around the Ferrari GT car

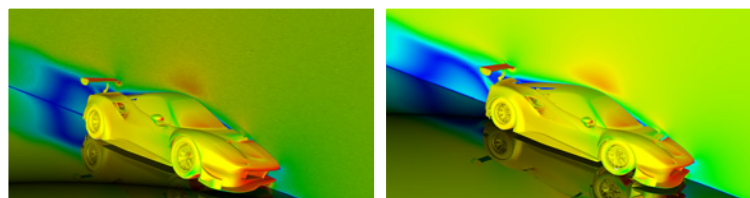

meant hours of hands-on time spent optimizing mesh quality — resulting in a large computational size and a correspondingly long run time for each CFD study.

By collaborating with ANSYS, the Ferrari Competizioni GT development team has achieved both a meaningful mesh resolution level and rapid results. By applying Mosaic-enabled poly-hexcore meshing capabilities in ANSYS Fluent, the Ferrari engineering organization has been able to achieve an even higher level of simulation accuracy with fewer cells, leading to less manual work and a much faster solution time. The Fluent solver handles hexcore cells very efficiently, leading to productivity gains.

This meshing capability also supports fully automated meshing, with little to no user intervention. Once a new design option has been defined, its surface mesh is automatically partitioned and sent to different cores of a distributed, parallel computing architecture. By batch executing the standard, repetitive tasks involved in meshing via Mosaic-enabled technology — combined with robust Fluent Meshing native scripting — even less-experienced engineers can realize a 4-times speedup in meshing speed and efficiency.

This means that Ferrari designers can look at a larger number of geometry options very quickly, thanks to the built-in automation of Fluent’s task-based meshing workflows. In the past, users had to create custom scripts to enable automated meshing in Fluent — but now an entirely new vehicle geometry can be introduced and automatically meshed in just a few hours.

Innovations in ANSYS Fluent such as Mosaic meshing have enabled tremendous workflow and productivity benefits for Ferrari Competizioni GT. This automated workflow boosts productivity by

reducing the user learning curve, minimizing the chance of human error, and freeing engineers to focus on higher-value work. This helps the Ferrari development team make significant changes every three years and prepare a new car for the racing season in less than a year, with a limited amount of resources.

Thanks to Mosaic-enabled poly-hexcore meshing, Ferrari engineers have been able to decrease the number of meshing cells by 15%. This reduction, when combined with the new hex-dominant mesh, delivers solution times that are twice as fast. For an organization focused on speed, that is an enormous improvement. By relying on Mosaic technology and the Fluent end-to-end workflow, Ferrari engineers can run three times as many CFD simulations in the same amount of time — and can develop cars faster than ever before.

“This automated workflow *boosts productivity* by reducing the user learning curve, minimizing the chance of *human error* and freeing engineers to focus on higher-value work.”

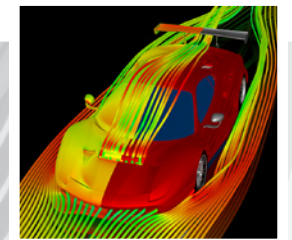

Mosaic-enabled meshing

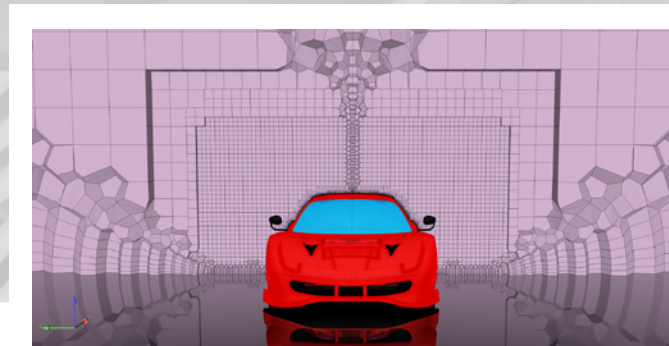

FERRARI’S PARTNERSHIP WITH ANSYS: A WINNING COMBINATION

GT competitive racing has always been part of Ferrari’s DNA. Ferrari Competizioni GT will race two cars in the 2019 season: the 488 GTE and the 488 GT3. These two turbo-engine cars will compete in the most demanding endurance races and the most important national and international GT series. The 488 GTE has already won two Manufacturers’ titles in the FIA World Endurance Championship, while the 488 GT3 has won more than 230 races, two IMSA GTD class titles and one Asian Le Mans Series Championship.

Ferrari’s partnership with ANSYS has been an important element in this successful track record. In the modern competition environment, simulation is essential to provide a reliable answer to the tough challenges associated with GT racing. Without simulation, no team stands a real chance of delivering results in a cost- and time-effective manner. Ferrari Competizioni GT’s use of advanced simulation capabilities from ANSYS, including the Mosaic meshing and the watertight workflow, has given the team a dramatic performance advantage on the track.

In June 2019, the Ferrari team driving the 488 GTE won the 24 hours of Le Mans for the 36th time, a monumental achievement.

Ferrari will always invest heavily in research and development, including engineering simulation, to make sure the company retains its edge as technologies change. Upgrading or adapting its cars, and constantly introducing new models, means that Ferrari must also stay ahead of the pack in adapting best-in-class engineering solutions. 🏎️

A Breakthrough in Air-Cooled Steam Condensers

By **Jean-Pierre Libert**
Vice President – Power
Product Development
EVAPCO, Inc.
Westminster, U.S.A.

Developing an air-cooled steam condenser for thermoelectric power plants is a balancing act: The goal is to maximize heat transfer, minimize pressure drop and constrain energy consumption and costs. Leading manufacturer EVAPCO, Inc., used ANSYS Fluent to design new heat exchanger fins for its air-cooled condenser – and their success led to the development of an entirely new heat exchanger configuration.

“ANSYS Fluent simulation delivered a 15% increase in thermal capacity and decreased cost significantly.”

ACCs route the turbine exhaust steam to an array of finned tube air exchangers.

Nearly all the electricity produced in the United States comes from thermoelectric plants. Historically, these facilities have relied on a water-intensive process: Water is boiled to create steam, the steam spins the turbines to generate electricity, and cold water cools the steam back to its liquid form in a condenser for reuse. Most power plants originally sourced water from rivers or lakes for the bulk of their cooling, but as environmental regulations expanded, power plants added evaporative cooling towers, first to reduce the temperature of the water returned to the source, and later in closed loops to further reduce the environmental impact. However, even by switching to evaporative cooling, significant amounts of water are still consumed.

As global water demand grew over the past several decades, legislators responded with water conservation laws. As a result, the number of power plants that employ air instead of water as the coolant is increasing. These facilities condense steam using ambient air, meaning no water is consumed. Although dry cooling systems do not eliminate the use of water in power plants, they come close: It is estimated that they decrease total consumption by more than 98%.

But water savings come with a trade-off.

Dry cooling systems require a larger upfront capital investment and typically require higher auxiliary power to operate.

To maximize the heat transfer capacity in its air-cooled steam condensers (ACC) while improving energy efficiency, EVAPCO, Inc., a leading manufacturer of evaporative and dry cooling products, used ANSYS Fluent to identify areas where it could improve the fin technology used in the heat exchanger tube bundles.

Modeling enabled a breakthrough that led to the development of the patent-pending Arrowhead™ fin design. The Arrowhead fin significantly improves heat transfer compared to current technology; it also limits the amount of energy needed to overcome pressure drop as air is forced through the heat exchanger.

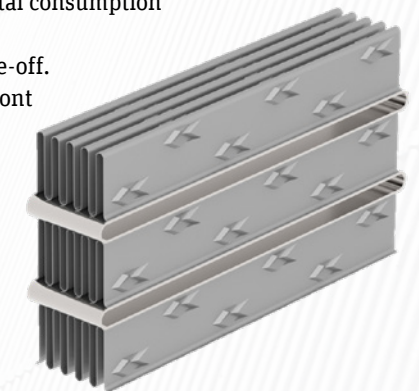

EVAPCO's Arrowhead™ fin

A VORTEX MOVES AIR BETTER, WITHOUT INCREASING PRESSURE DROP

ACCs route turbine exhaust steam to an array of finned tube air exchangers where ambient air serves as a cooling fluid. Air is forced at high velocity between the fins to condense the fast-moving steam, which may be traveling at speeds of up to 125 meters per second inside the tubes.



EVAPCO applied the successful concept of microchannels to the ACC heat exchanger tubes.

The purpose of the fins is to extend the heat transfer surface to create more surface area for cooling. Fin designs that include ripples, corrugations and dimples further increase heat transfer but at the expense of greater pressure drop. While it is possible to compensate for pressure drop by increasing the fan motor power to push more air through the heat exchanger, this adds to the

parasitic energy and operating costs of the installation.

Engineers designing air-cooled condensers are faced with the challenge of maximizing heat transfer capacity, minimizing air-side pressure drop, and limiting energy consumption and capital costs. To achieve this balance, EVAPCO modeled hundreds of fin geometries in ANSYS Fluent to characterize heat transfer and pressure drop properties. Simulations focused on improving vortex generation: Vortices enhance heat transfer by promoting air mixing between the fins while minimizing increases in air-side pressure drop. After EVAPCO engineers discovered that a certain type of vortex moved the air more efficiently without increasing pressure drop, they used this knowledge to develop the Arrowhead fin technology.

“Employing ANSYS Fluent to maximize heat transfer while minimizing pressure drop, EVAPCO created a leading-edge heat transfer product for the global power generation industry.”

Using ANSYS Fluent computational fluid dynamics software saved the company the time and expense of building and testing what could have been as many as 100 prototypes. More importantly, even if EVAPCO had done that much prototyping, without the knowledge gained from utilizing ANSYS Fluent its engineers still might not have had the same insight into air vortices or how to make the fin design more efficient.

SIGNIFICANT IMPROVEMENTS IN THERMAL CAPACITY, PLUS COST SAVINGS

After EVAPCO determined an efficient fin design, the company maximized its benefits by improving the entire heat exchanger system. Engineers applied the successful concept of microchannels from other heat transfer industries to the ACC heat exchanger tubes. By studying steam flow inside the tubes with ANSYS Fluent, EVAPCO engineers were able to develop modified tube geometries to optimize steam-side pressure drop.

Fluent allowed engineers to investigate internal steam flow fields inside the piping and header of the heat exchanger and provided new knowledge about inlet pressure drop losses, which varied in every tube. Fluent also enabled EVAPCO engineers to investigate flow-accelerated erosion and create internal structures to minimize its potential. That included ensuring good flow inside the steam header and avoiding choking the flow in the tubes. The information gained from this analysis was instrumental in creating the final header design.

The combination of the new Arrowhead fin technology with the improved tube geometry resulted in the nuCore™ heat exchanger. nuCore greatly improves heat transfer across a wide range of operating conditions to minimize the ACC surface area requirements and reduce material costs.

Using Fluent simulation as part of EVAPCO’s fin research and development and redesigning the heat exchanger configuration with the new fin and tube technology resulted in a significant increase in thermal capacity of at least 15%.

UNPARALLELED SUPPORT LEADS TO A BETTER HEAT TRANSFER PRODUCT

Prior to choosing ANSYS Fluent, EVAPCO engineers had used a simpler computational fluid dynamics software, but they found it too limited to tackle the work of improving their heat exchanger tube fins. Going into this project, they evaluated three products, including ANSYS Fluent. In addition to looking at each simulation system’s technical strengths, they considered tech support, training and whether they could buy or rent the product — and concluded that nothing could compare to ANSYS’ support capability, including personalized training that helped them create some of their initial models with the highest accuracy and speed of calculation.

By employing ANSYS Fluent to maximize heat transfer while minimizing pressure drop, EVAPCO created a leading-edge heat transfer product for the global power generation industry — one that is more efficient, more compact and less costly to operate. It also helps meet the needs and requirements of a water-conscious world. ⚠️



Air-cooled steam condensers

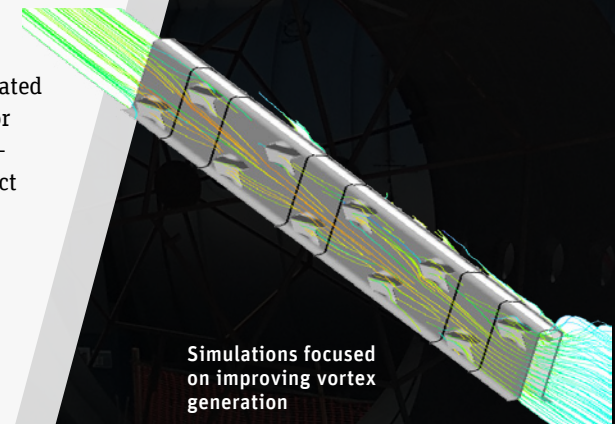

Simulations focused on improving vortex generation

When the Pressure is On: Preventing Well Blowouts



The appearance of U.S. Department of Defense (DoD) visual information does not imply or constitute DoD endorsement.

By **Amy McCleney**
Research Engineer –
Computational Fluid Dynamics
Southwest Research Institute
San Antonio, U.S.A.

To understand what stopped emergency devices from deploying fully during an offshore well catastrophe, researchers turned to ANSYS Mechanical and ANSYS Fluent to model fluid–structure interactions. The result of this landmark work has the potential to change the regulatory framework for blowout preventers and is helping manufacturers better ensure the integrity of their products.

A year after it made history for drilling the world’s deepest oil well, the Deepwater Horizon rig lay wrecked on the floor of the Gulf of Mexico.

Heralded as a model of safety by the U.S. Minerals Management Service, the rig sank after an explosion that killed 11 crewmen and set off the largest oil spill in U.S. waters. Millions of barrels of oil were released into the Gulf of Mexico.

Investigators could not reach the seabed to find out what happened firsthand, but they did have access to real-time data. In the end, they determined that a chain of malfunctions contributed to the disaster, including a blowout preventer (BOP) that failed to

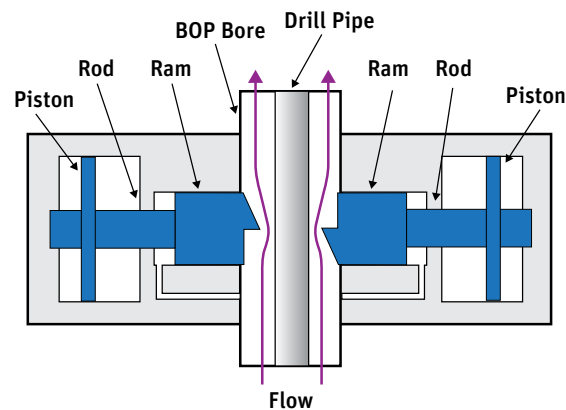

Simplified diagram of a blind shear ram

work as designed. Instead of shearing the drill pipe and sealing the wellbore, the faulty BOP allowed pressurized contents to travel unimpeded up the pipe, igniting a fireball that could be seen 40 miles away.

To understand what happened, prevent similar catastrophes and help BOP manufacturers better manage product integrity, the Southwest Research Institute (SwRI) developed and validated a model to analyze how offshore BOPs are likely to function during an emergency. Working with drawings and mechanical CAD files furnished by three BOP manufacturers, SwRI coupled ANSYS Fluent CFD and ANSYS Mechanical to analyze the equipment under the high-pressure, high-flow conditions experienced in deep-water Gulf of Mexico.

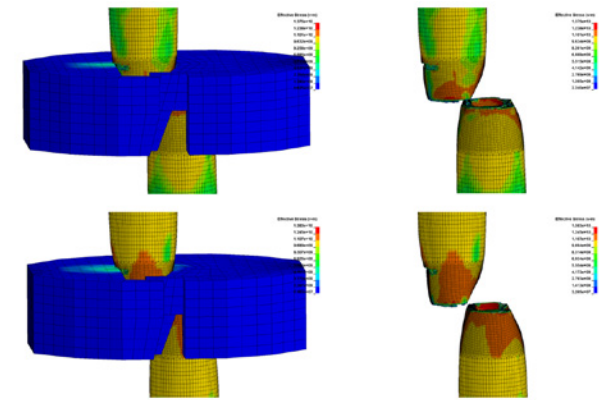

ANSYS Mechanical simulation showing stresses on the cut pipe

Obviously, there is no way to replicate the highly complicated process of pinching and cutting off high-strength steel pipe under full-scale field conditions: The extreme pressure and flow make it impractical, if not far too dangerous. SwRI coupled ANSYS Mechanical and ANSYS Fluent to model how extreme pressure and flow features affect a solid BOP structure.

CLOSING THE INTEGRITY GAP

SwRI’s work was funded by the U.S. Bureau of Safety and Environmental Enforcement (BSEE) as part of their effort to advance the design of BOPs so they function effectively during a blowout.

“ANSYS software was part of the first-ever modeling approach that demonstrates how pipeline flow conditions can affect BOP performance.”

A FIRST-OF-ITS-KIND SIMULATION

BOPs have one job, and it is a big one: They are the last line of defense during an uncontrolled release of crude oil or natural gas from a well. When activated, the BOP’s blind shear ram — an emergency hydraulic device with two sharp cutting blades — closes around the drill pipe connecting the rig to the well, pinching it shut then severing it. This seals off the wellbore.

In the case of the Deepwater Horizon, however, the blind shear ram did not work as planned. The blades punctured but failed to cut clear through the pipe. It was not pinched shut. As a result, a hazardous mixture of oil, gas, drilling fluids and contaminants ranging from sand to rock cuttings surged from the out-of-control well to the surface.

For BOP manufacturers eager to avoid incidents like that, understanding the dynamics of the event is essential.

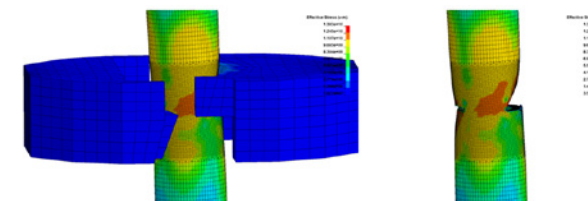

ANSYS Mechanical simulation showing stresses on the pipe

The regulator requires independent third-party verification of the capability of a blind shear ram to cut and seal pipe under all operating conditions, but lacked testing criteria, making it impossible for BOP manufacturers to comply.

Historically, manufacturers measured BOP integrity based on material properties but had no way to assess how the blind shear ram would perform during either normal or extreme conditions.

To close the gap through simulation modeling, SwRI considered three factors:

- The mechanical force required to deform and shear the drill pipe
- The hydrostatic force within the BOP
- The hydrodynamic force caused by acceleration of the fluid as it flows around the angled surfaces of the shear ram

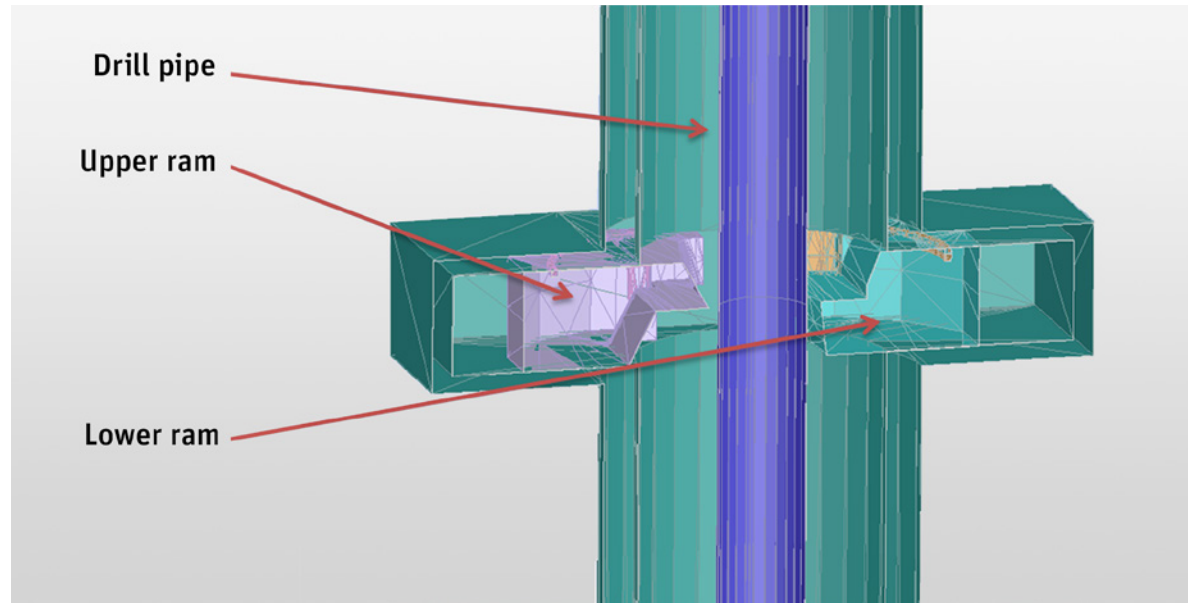

CAD model for CFD simulation

“ANSYS software allowed fluid–structure interaction (FSI) simulation under a variety of flow conditions.”

Their analysis assumed a worst-case scenario — a release volume of 100,000 stock tank barrels per day (stb/d) under flowing pressures and fluid properties representative of outer shelf Gulf of Mexico conditions.

Using ANSYS Mechanical, SwRI first modeled the interaction of the closing blind shear rams and drill pipe. Next, they used ANSYS Fluent CFD to predict how hydrodynamic forces would change as fluid moved through a gradually closing pipe, with the expectation that the local flow in the annulus — the void between the drill pipe and the blades — would accelerate as it moved through the reduced cross-sectional area remaining open to flow.

The team at SwRI’s fluids engineering department simulated three different rams closing at different speeds. ANSYS software allowed fluid–structure interaction (FSI) simulation under a variety of flow conditions, including changes in density, viscosity, flow rate and pressure. Turbulence was also considered.

That initial stage was followed by a mesh refinement study and a four-tier fluid–structure interaction simulation that added a layer of physics each time. In this approach, geometries from

ANSYS Mechanical were imported into ANSYS Fluent to solve for the hydrodynamic forces on the rams.

- The first tier, which served as a reference for tiers 2 through 4, included finite-element analysis of the shear rams and tubing geometry, without the addition of a hydraulic force.
- Tier 2 coupled FEA shearing forces and CFD fluid forces at various fractional openings of the annulus.
- Tier 3 was similar to Tier 2 but used different fractional openings.
- Tier 4 coupled FEA and CFD solvers to run the complete fluid–structure interaction problem.

UNDERSTANDING THE IMPORTANCE OF FLUID–STRUCTURE INTERACTION

Before SwRI’s work, the effect of fluid hydrodynamics on blind shear rams was assumed to be negligible compared to mechanical and hydrostatic forces. Through their use of ANSYS Fluent and ANSYS Mechanical, SwRI demonstrated how the

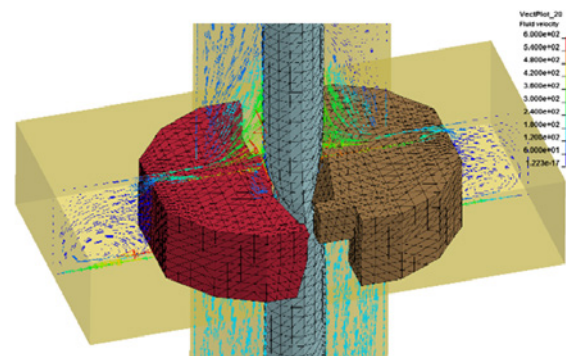

Multiphysics CFD and FEA simulation

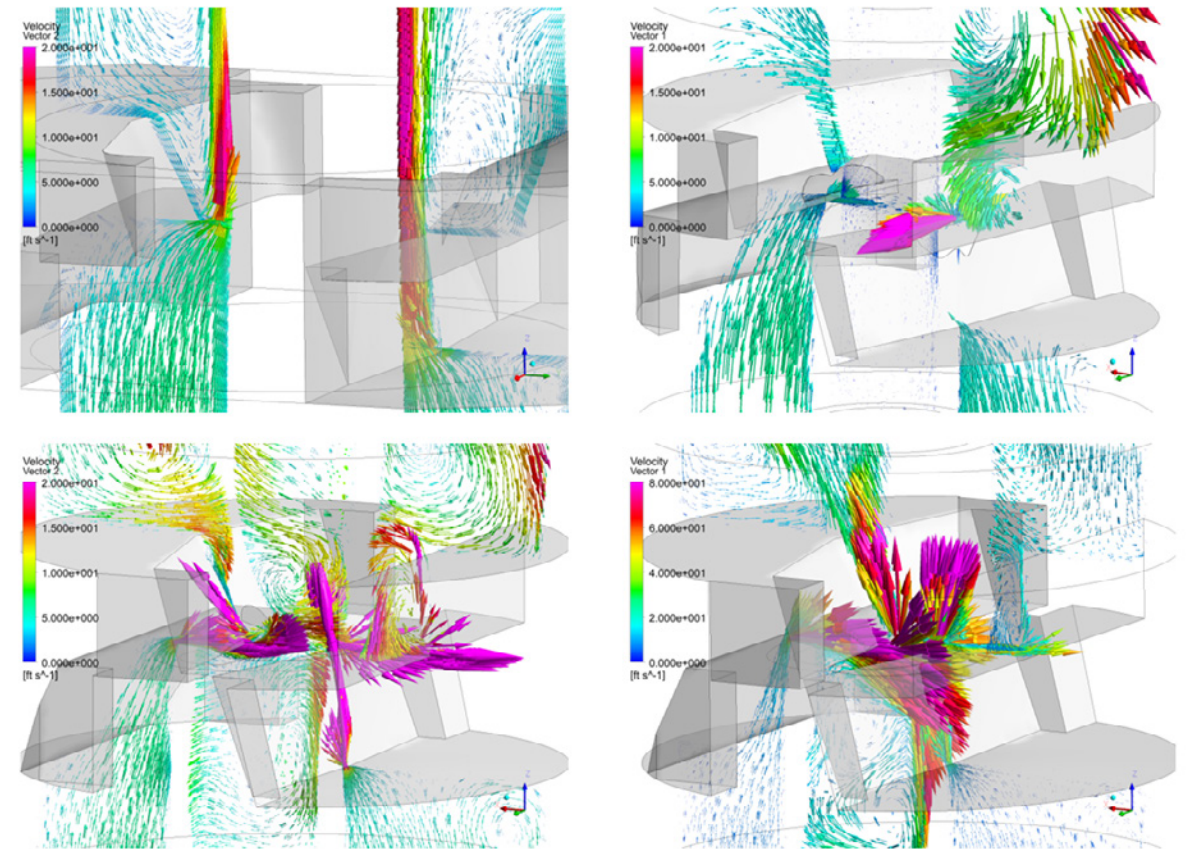

CFD flow fields with the ram closing on the pipe

“SwRI developed and validated a model to analyze how offshore BOPs are likely to function during an emergency.”

simultaneous effects of flow rate and fluid pressure interact with the structural dynamics of severing a drill pipe. They used both one-way and two-way coupling, but, after determining that one-way coupling was sufficiently accurate for this application, much of the study focused on one-way coupling. The work accurately predicted the hydrodynamic forces exerted on the rams as they close on the flow, demonstrating subsea BOP shear and seal capabilities under deep water, loss-of-control conditions. The results have the potential to change the regulatory framework around the shearing performance of BOP devices. At the very least, they indicate to BOP manufacturers that material properties testing alone is not enough to ensure the BOP’s integrity.

SwRI regularly uses ANSYS software because of its dependability. In this case, where it was necessary to study fluid–structure interaction, the way ANSYS Fluent coupled seamlessly with ANSYS Mechanical was particularly useful.

SwRI’s work with BSEE is not over: The team will build upon the work completed by adding erosion and multiphase simulation. The team will once again use ANSYS Fluent, which has an erosion package and highly trusted multiphase modeling approaches.

TOWARD AN EVEN SAFER INDUSTRY

The oil and gas industry makes safety a priority. Failures rarely occur, but as the Deepwater Horizon example indicates, when they do, the results can be catastrophic. Understanding how BOPs perform during a blowout has been an issue for operators and regulators alike.

By using ANSYS software to develop the first-ever modeling approach that demonstrates how pipeline flow conditions can affect BOP performance, SwRI is helping the industry and regulators address this concern and making it easier for manufacturers to comply with requirements. ⚠️

Generating Hydrogen for Energy Storage



By **Ernesto Amores Vera**
 Research and Development Engineer
 Centro Nacional del Hidrógeno (CNH2)
 Ciudad Real, Spain

An increase in renewable energy production has fueled interest in proton-exchange membrane water electrolysis as a viable solution to generate hydrogen to store power. To optimize and improve proton-exchange membrane (PEM) cells, a national project called ENHIGMA uses ANSYS Fluent as the fundamental tool to simulate the flow field in these cells. The results from the simulations will help the future manufacture of more cost-competitive, efficient and durable PEM electrolyzers.

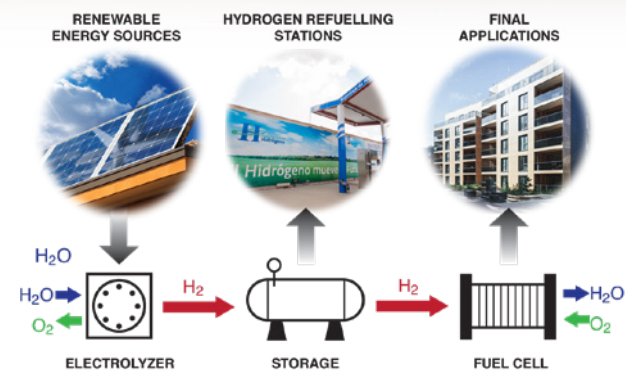

Hydrogen energy cycle: production, storage and transformation. Excess renewable energy production can be used by a water electrolyzer to produce hydrogen and oxygen. The hydrogen can be transported or stored in appropriate facilities, then when it is needed, hydrogen can be transformed into electricity using a fuel cell or it can be used as fuel in the mobility sector.

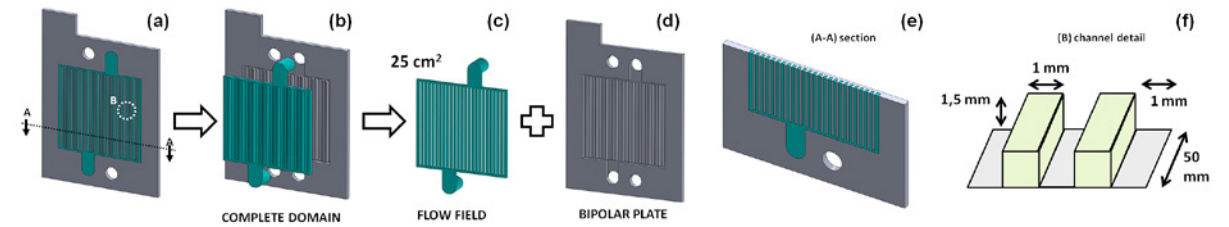

Geometry for the simulation model: (a) bipolar plate with the flow distribution channels; (b) complete domain; (c) parallel flow field; (d) bipolar plate; (e) section of the channels of the bipolar plate; (f) detailed dimensions of the channels

As demand for energy rises, the world requires more secure and reliable sources of electricity. This has accelerated innovation in energy production using many new technologies. However, many renewable energy sources (RES) such as solar, wind and others do not continuously produce electricity at a consistent rate. New and adequate energy storage is required to overcome the intermittency of RES and successfully integrate them into the power supply.

The storage capacity of batteries is often limited to hours or a few days. Hydrogen, an energy carrier, can be stored for indefinite periods. It can be produced from electricity generated by RES and, once stored, hydrogen can be transported and distributed for use, such as within hydrogen refueling stations in the mobility sector. It can also be reconverted to electricity with a fuel cell to power electric vehicles or a home, or be supplied to the grid.

Water electrolysis is one of the most environmentally friendly ways to produce hydrogen. In this electrochemical process, electricity is applied to split water, which produces hydrogen and oxygen. When the electricity comes from renewable energy sources, it is a zero-emission process.

Among the different electrolysis processes, proton-exchange membrane water electrolysis (PEMWE) has become one of the most important. PEMWE systems

“New and adequate energy storage is required to overcome the intermittency of renewable energy sources.”

can operate at high current densities (2,000 mA/cm²) to generate hydrogen of high purity and high pressure. While there are large-scale commercial PEM electrolyzers in use today, various challenges, including high cost and durability, prohibit their widespread adoption.

The Centro Nacional del Hidrógeno (CNH2) (the Hydrogen National Center) in Spain carries out research into future technologies like hydrogen and

fuel cells. CNH2 is the technical coordinator of the ENHIGMA project (2016–2019) and, with other research centers and companies, is investigating ways to develop a low-cost, durable and energy-efficient PEM electrolyzer.

VITAL COMPONENT IN THE DESIGN

The bipolar plates (BPs) are some of the most important components in a PEMWE. Providing structural strength, these metal

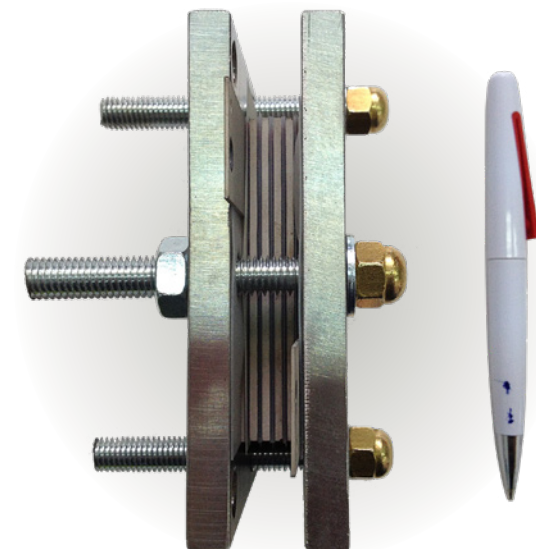

A PEM water electrolysis stack for hydrogen production with purity higher than 99.995%. The active area is 25 cm² and the maximum current density of 2,000 mA/cm².

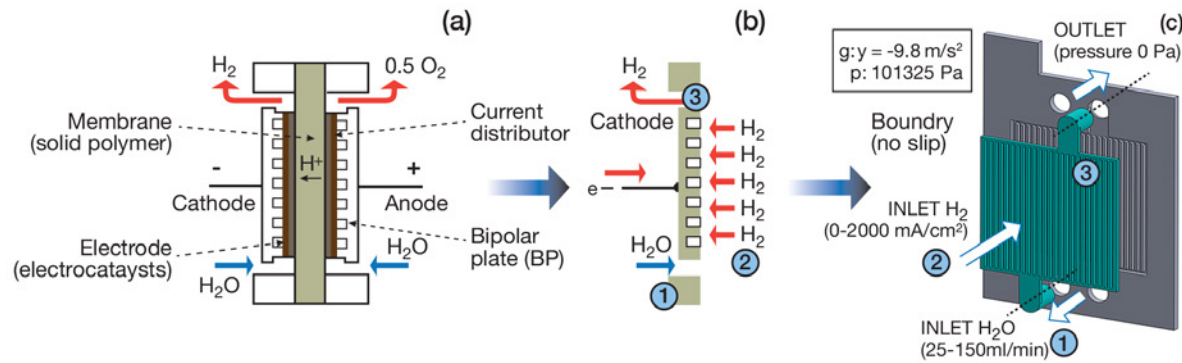

Model setup for the flow field in a PEM water electrolysis cell: (a) simplified scheme of a complete cell; (b) domain of the cathodic chamber considered in the model; (c) phenomena considered in the channels of the cathode

plates separate each membrane-electrode assembly (MEA) in a PEMWE stack. They feature machined flow channels that distribute the water inside the cell and carry the generated gases (H_2/O_2) to the outlets. They are also essential for sufficient electrical conduction to the reaction points and for the dissipation of heat. BPs account for approximately 50% of the costs of PEMWE due to the materials and manufacturing method used, so improving PEMWE requires the optimization of this component.

Computational fluid dynamics (CFD) simulation is fundamental in obtaining information about the flow distribution in the BPs. The ENHIGMA research team used ANSYS Meshing and then ANSYS Fluent to solve the various complex CFD simulations. With CNH2's high-performance computing license (ANSYS HPC), the research team could divide the various calculations among the eight cores it has in-house for parallel processing to solve the complex CFD simulations quickly and cost-effectively.

DEVELOPMENT OF THE MODEL

A variety of possible flow field configurations can be used for the water flowing in a PEMWE cell, but the straight parallel channel geometry is often considered the best design for flow distribution due to its simplicity. The project

“These results will help contribute to the future manufacture of better-performing, lower-cost, energy-efficient and durable PM electrolyzers.”

team chose this configuration to model in the simulations. To simplify the models, they analyzed the flow distribution only in the cathode chamber using the ANSYS Fluent PEMWE model. ANSYS Fluent also has other fuel cell models, including those for PEM and solid oxide fuel cells (SOFC).

The first step in the process was to perform a mesh independence study in ANSYS Meshing to determine the optimal number of nodes for the simulation.

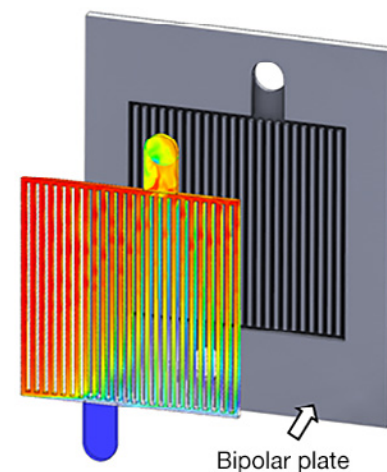

Seven meshes were evaluated to determine the best discretization, with the optimal number being 1,901,570 nodes.

ANSYS Meshing easily enabled researchers to mesh complex geometries so they were able to create suitable meshes for different zones in the same model. For example, they used a hexahedral mesh for the channels and a tetrahedral mesh for the inlet/outlet of the BPs.

Hydrogen fraction in an electrolysis cell when straight parallel channels are used in a bipolar plate. The flow distribution is deficient in the middle channels. As a result, hot spots and inefficient hydrogen production can occur in the lateral channels.

SIMULATING THE FLOW FIELD

The team used ANSYS Fluent software to simulate the flow field in the models of interest. To predict the flow of water as it enters the cell and is distributed through the channels, Fluent solved equations for conservation of momentum, continuity and energy.

Using Faraday's law of electrolysis, the team then calculated the hydrogen generation rate as hydrogen flowed from the membrane-electrode assembly (MEA) to the channels when a potential difference was applied between the electrodes (auxiliary equation). This equation is introduced into the model as a velocity boundary condition (current density versus hydrogen flow rate).

Next, as the water and hydrogen generated moved in the channels to the cell outlet, the team needed to calculate multiphase flow. In a PEMWE, there is a main phase (water) and a second phase (small hydrogen bubbles) dispersed within the main phase. Calculating multiphase flow is complex as several phenomena occur in a liquid-gas mixture. Instead of using a full Eulerian multiphase model, the team created a mixture model in ANSYS Fluent. This is a simpler model that performs as well as a full multiphase model while requiring a smaller number of variables. Typical applications include bubbly flows where the gas volume fraction remains low. Using this mixture model method, the volume fraction equation for liquid and gas phases was obtained.

RESULTS FOR IMPROVED DESIGNS

With the simulations complete, the research team could then analyze the results. When looking at the hydrogen volume fraction in an electrolysis cell at different flow rates, the results showed that when the water flow increases from 25 to 100 mL/min for a given current density, the flow distribution was

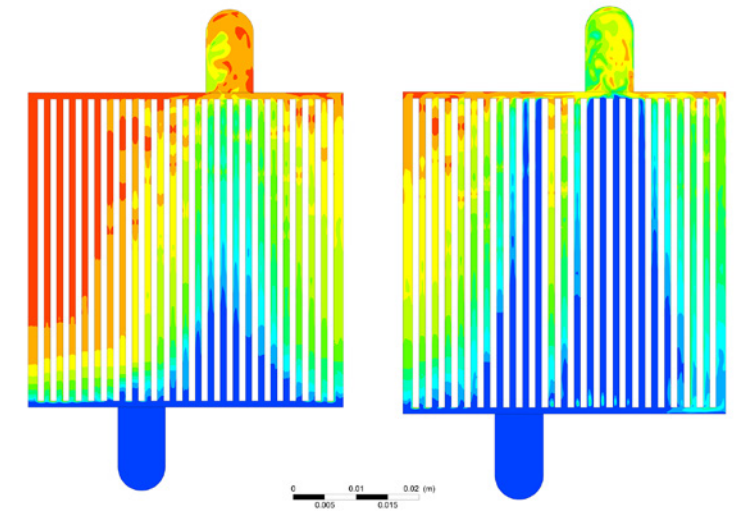

Hydrogen fraction in an electrolysis cell at different flow rates with straight parallel channels. When the water flow increases from 25 (left) to 100 (right) mL/min for a given current density, the flow distribution is deficient in some channels.

deficient in some channels. The same was true with the results for mixture density, with channels being increasingly blocked when the current density increases. The results revealed that when the current density changes from 500 to 2,000 mA/cm² for a given flow rate, the hydrogen produced tends to fill the channels having a relatively lower flow velocity, blocking the passage of water in those channels.

Although a straight parallel channel configuration in the BPs is often considered the best configuration for the flow field, the results obtained using CFD simulation in ANSYS Fluent revealed that this is not the case. There are significant weaknesses in the proposed design, especially at high currents and high flow rates, which causes hot spots and reduces the efficiency of the process. A new flow distribution configuration had to be proposed.

CONTRIBUTING TO A HYDROGEN FUTURE

The goal of the ENHIGMA project is to obtain results that will improve the commercial feasibility of PEM

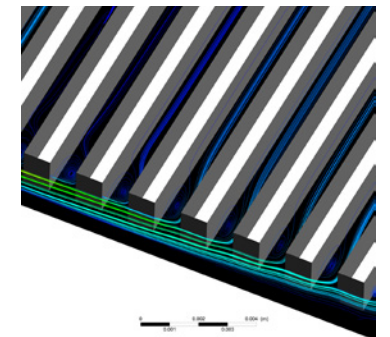

Streamlines at the closest part of the bipolar plate to the channel inflow at 500 mA/cm² and 100 mL/min. In some channels, when the flow rate is high, vorticity phenomena may occur. This limits the water flow in each channel so that the hydrogen generated in the cell accumulates, reducing the efficiency of the process.

electrolyzers. Fundamental to this is the optimization of a key component, the BPs. Through various CFD simulations of this component in ANSYS Fluent, the research team has gained conclusive preliminary results of the flow field in PEM water electrolysis. These results will contribute to the future manufacture of better-performing, lower-cost, energy-efficient and durable PEM electrolyzers.

Rewriting the Formula for Fireworks

What is the secret for making fireworks shows look more spectacular? By leveraging simulation to reduce the amount of fireworks smoke, the displays will be brighter and more dynamic than ever. Mitsuo Koshi, a highly respected chemical kineticist and fireworks contest judge, tackled this problem.

By **Mitsuo Koshi**
Professor Emeritus
University of Tokyo
Japan

Every summer in Japan, dozens of “Hanabi” aerial fireworks festivals light up the night sky. These events attract hundreds of thousands of visitors, with many camping out hours in advance to grab the best viewing spots. However, during calm weather, spectators suffer from reduced visibility due to large clouds of smoke generated by the explosive combustion of black powder within the fireworks. The issue worsens every year as the festivals — and fireworks manufacturers — compete by creating bigger and more elaborate fireworks displays to sell more tickets.

To solve the problem, ANSYS Chemkin-Pro — software predominantly used for creating combustion simulations — was used to model the smoke formation within the fireworks and investigate the chemical reactions. This data provided invaluable insights that led to recommendations for smoke reduction.



SIMULATING SMOKE FORMATIONS

The first attempt to understand the phenomena involved used classical nucleation theory (CNT) to crack the smoke formation code, hoping to reveal the mechanisms for particle formation and the related physics. Unfortunately, CNT could not be applied to examine the fireworks’ very small particles and predict how black powder generates smoke.

To overcome this challenge, an unconventional approach was attempted using Chemkin-Pro, the same combustion modeling tool that automobile manufacturers use to predict soot formation in their car engines. Soot is composed of hydrocarbons, and fireworks smoke is composed of potassium salt.

Modeling research efforts began by predicting the gas concentration within the fireworks’ chemicals. By creating a simple reaction/kinetics model as an input to Chemkin’s particle tracking system, Chemkin predicted the smoke’s particle sizes and particle number densities based on processes such as coagulation and aggregation, leveraging Chemkin-Pro’s particle tracking system to enable particle calculations. This approach produced a holistic view of the problem, leading to a solution of the master equation for the particle population and a recommendation to mitigate smoke generation, all in just one month.

Without simulation, predicting particle size, distribution and density would have been nearly impossible. Determining these values using experiment only would have been very expensive.

Additionally, simply focusing on experiments would not have permitted an analysis of smoke formation. Understanding the chemistry and physics behind potassium salt particle formation in black powder combustion was vital to answer the critical questions.

ENGINEERING A NEW RECIPE FOR FIREWORKS

Simulation led to a recommendation to alter the formula for fireworks chemistry, substituting ammonium perchlorate for large amounts of black powder while reducing the amount of potassium salt in the black powder recipe. This approach slashed the number of smoke particles and reduced emitted smoke by nearly 90% — leading to higher-quality fireworks displays.

Next, researchers from the Yokohama National University and the University of Tokyo will conduct extensive experiments based on these models, using

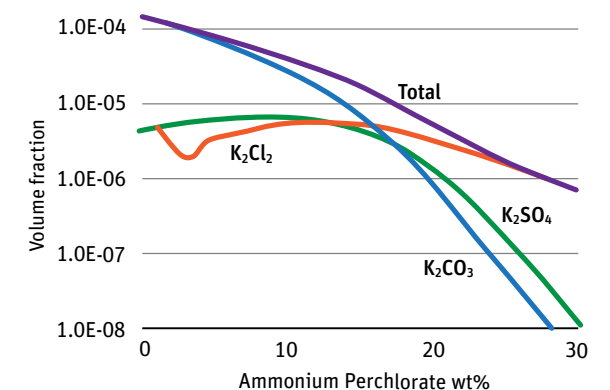

Average volume fraction of smoke particles after black powder combustion obtained by solving the Smoluchowski equation using ANSYS Chemkin-Pro as a function of added ammonium perchlorate.

Introduction to ANSYS Chemkin for
Chemical Kinetics Simulation
ansys.com/chemkin-intro

“ANSYS Chemkin-Pro was used to model the smoke formation within fireworks and investigate the chemical reactions.”



state-of-the-art instruments to measure the smoke and test the conclusions derived from the modeling.

Interestingly, this fireworks research can be applied to other applications, processes and industries. For example, the beauty industry consistently seeks new methods to reduce the size of hydrogen dioxide, titanium dioxide and aluminum nitride nanoparticles in makeup, which in turn produces a higher-quality product. To accomplish this, a reaction/kinetic model input into Chemkin-Pro would enable the modeling of particle coagulation and other key processes, providing researchers with key insights for shrinking the nanoparticles.

Japanese fireworks festivals will soon brighten and have more visibility than ever thanks to this cutting-edge research. Simulation quickly enabled a feat formerly deemed impossible — nearly eliminating the smoke from fireworks — by rewriting the formula. 📌

ABOUT MITSUO KOSHI

Professor Mitsuo Koshi is a world-renowned chemical kineticist and chairman of Japan's Fireworks Festival Committee, responsible for judging the most prestigious fireworks competitions in Japan. An expert on combustion reaction modeling and chemical kinetics/reactions of explosives and former chairman of the Japan Explosives Society, Koshi recently offered his expertise to the Japanese fireworks industry to help overcome the engineering challenge of reducing fireworks smoke, enabling every fireworks show in Japan to deliver the highest-quality experience.

Reference

Koshi, M. Smoke Generation in Black Powder Combustion. **2018**. *Science and Technology of Energetic Materials*, Vol. 79, Issue 3.



Reacting Flows and Combustions
[ansys.com/reacting-flows](https://www.ansys.com/reacting-flows)

CFD for Injection Molding



Plastic parts designers need to ensure that injection molded parts are fully formed and contain no visual defects. Specialized injection molding tools have been used to meet these goals for a very long time and have continued to mature. However, these tools require their own licensing, user training and support. In almost all cases, when specialized tools are optimized for injection molding, they become very limited for use in other engineering applications. Schneider Electric engineers have validated the use of ANSYS general-purpose computational fluid dynamics (CFD) software, which is already extensively used at Schneider Electric, for mold-filling simulation. They have also shown that ANSYS CFD can interface with a wide range of other simulation tools.

By **Carlos Marquez**, Thermal Domain Leader, CAE R&D and 3D Simulation and **Silvestre Cano**, Rheology Domain Leader Schneider Electric, Monterrey, Mexico
Omar Rodriguez, CFD Specialist Grupo SSC, San Miguel de Allende, Mexico

Manufacturability ranks second to function as a design concern for injection molded plastic parts. During the design process, engineers need to know how a part's material, geometry, gate locations, runner system, wall thicknesses, injection flow rate and other parameters will affect the cycle time and quality of the finished

part. The cost of the tool required to mold the parts is typically tens to hundreds of thousands of dollars. It is expensive to try to fix problems or optimize the design once a trial is underway, so simulation is required in the mold-filling process to identify quality issues and optimize productivity before building the injection molding tool.

Schneider Electric is leading the digital transformation of energy management and automation in homes, buildings, data centers, infrastructure and industries. For more than 180 years, Schneider Electric has innovated at every level, developing connected technologies and solutions for safety, reliability, efficiency and sustainability, and to ensure that “Life Is On.” The company's engineers wanted to determine whether injection molding simulation could be



An Introduction to Using UDFs
in ANSYS Fluent
[ansys.com/udf-intro](https://www.ansys.com/udf-intro)

performed with the already deployed general-purpose ANSYS Fluent CFD software used throughout Schneider Electric for a wide range of simulation tasks. If it could, the team would be able to meet their injection molding simulation needs while consolidating software tools. They could save costs by decreasing the number of licenses required, reducing the learning curve to increase team efficiency and alleviate additional training needs, and shrinking IT overhead.

DEFINING MATERIAL PROPERTIES

When simulating injection molding, engineers must account for the material properties of the polymer. Polymers have a high resistance to flow (viscosity) that is shear-dependent (meaning that portions of a fluid flow at different relative rates). The higher the shear, the lower the viscosity becomes, so typically polymers can be described as shear-thinning non-Newtonian fluids. This high shear rate occurs when the polymer is squeezed or forced to flow through narrow gaps.

This viscosity–shear-rate dependence makes the flow prediction of non-Newtonian polymers somewhat nonintuitive. For example, when the molten plastic is injected through a small gate into a large mold, the material flows outward to the walls of the mold. The outer layer flows more slowly than the inner core.

To leverage ANSYS CFD to simulate mold filling, Schneider engineers began by gathering physical properties on the plastics frequently used by the firm, such as the relationship between shear rate and viscosity. They fit the data to a non-Newtonian model and created a user-defined material in Fluent that represents each of the six primary materials used for injection molding at Schneider: polypropylene, polycarbonate, polyamide, polyester, polyethylene, polyphenylene and polyoxymethylene. This methodology could also be extended to other plastics if needed.

MOLD-FILLING TEST CASE

Schneider engineers selected an enclosure for a current transformer, used to measure alternating current, as a test case to evaluate the new methodology. In a current transformer, current in its secondary windings is proportional to the current flowing in its primary windings. The engineers imported a solid model of the enclosure into ANSYS DesignModeler. They eliminated details that were not relevant to the mold-filling simulation, such as chamfers and text embossing on the part, to optimize computational time. The geometry of the part was used to define the flow domain for the mold-filling simulation. Engineers defined a gate with a pressure boundary condition to shoot molten plastic into the mold. They created several user-defined functions (UDFs) to track important mold-filling parameters. For example, one of these functions tracks the unfilled area of the mold, providing a record of filling time and making it possible to stop the simulation when the mold is full to avoid wasting computational resources. Engineers ran the simulation from the beginning of the injection process to the point where the mold was filled with plastic. The simulation results correlated well with the results from the specialized mold-filling software.

Schneider engineers simulated the part to improve the mechanical properties of the transformer enclosure. They simulated mold filling with several materials to determine the effect the material change would have on part quality and productivity. Simulation predicted the locations of weld lines (produced when two flow fronts meet and are not properly welded together); the engineers could then evaluate problems in weld line formation. If the temperature and pressure of these flow fronts are not correct, the mechanical properties of the current transformer can be compromised. Engineers evaluated different gate positions and runner system designs to ensure that the part fills evenly and to minimize runner volume to avoid wasting material and energy. They evaluated different process settings to minimize warpage and sink marks, and to improve the structural integrity of the part.

ANSYS CFD MATCHES SPECIALIZED SOFTWARE

Engineers concluded that the general-purpose ANSYS CFD software provides the same accuracy as the niche tools that perform only injection molding simulation. This provides an opportunity to consolidate simulation software and could lead to substantial cost savings by reducing licensing, support and training costs. Using an ANSYS Workbench tool (ANSYS Fluent) for mold filling will also allow use of other ANSYS tools for other physics — such as structural integrity and electronics cooling — by leveraging a common model for multiple simulations. Finally, ANSYS CFD provides world-class parallel scalability that opens the door to cloud computing platforms. 🚀

Reference

Schneider Electric, schneider-electric.com

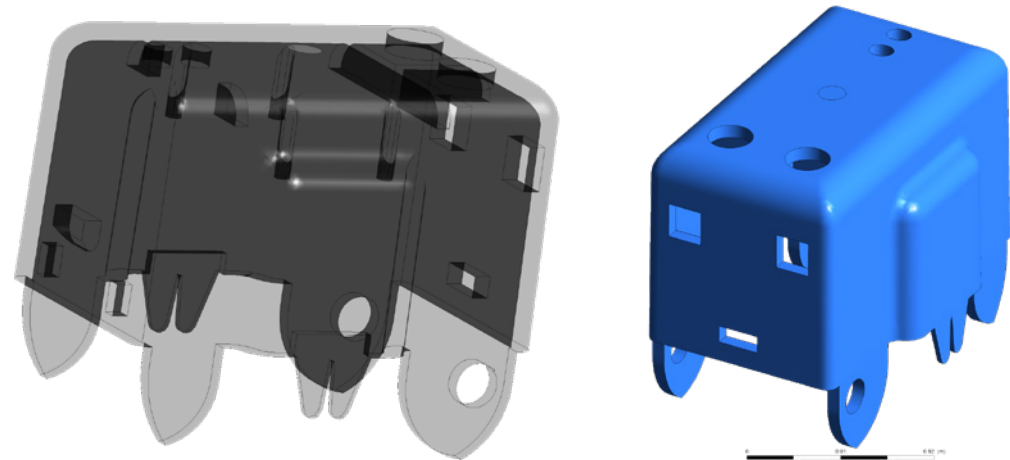

CAD models of the switch enclosure

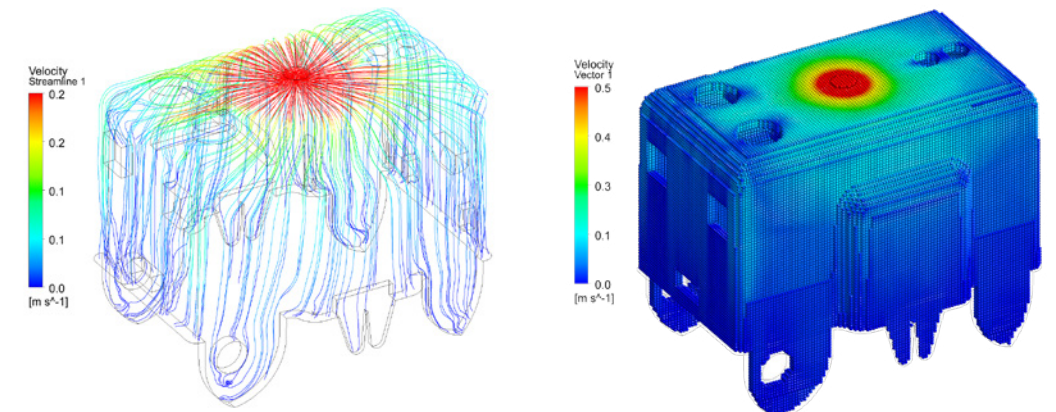

ANSYS Fluent mold-filling simulation predicts weld lines.

Velocity vectors of the plastic filling the mold

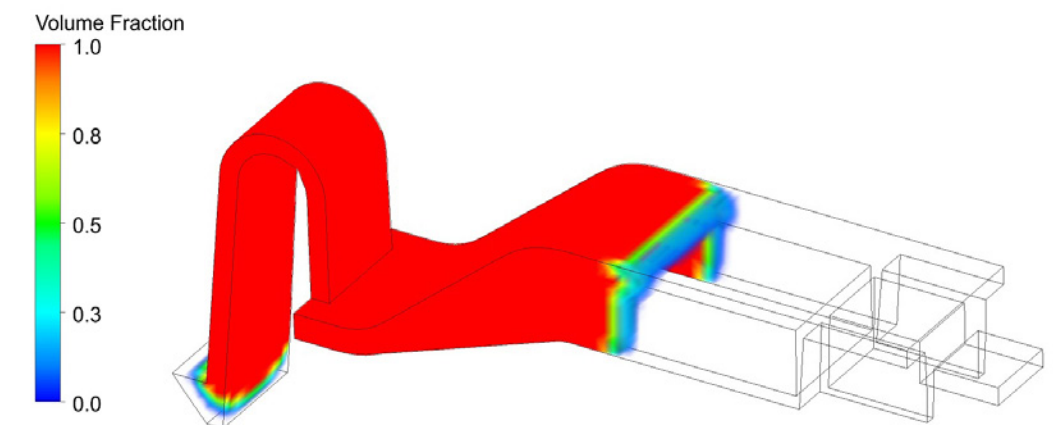

Volume fraction of plastic filling the mold

Flush with Innovation

By simulating the performance of many different toilet geometries, Roca engineers were able to cut both development time and prototyping costs by 66%.

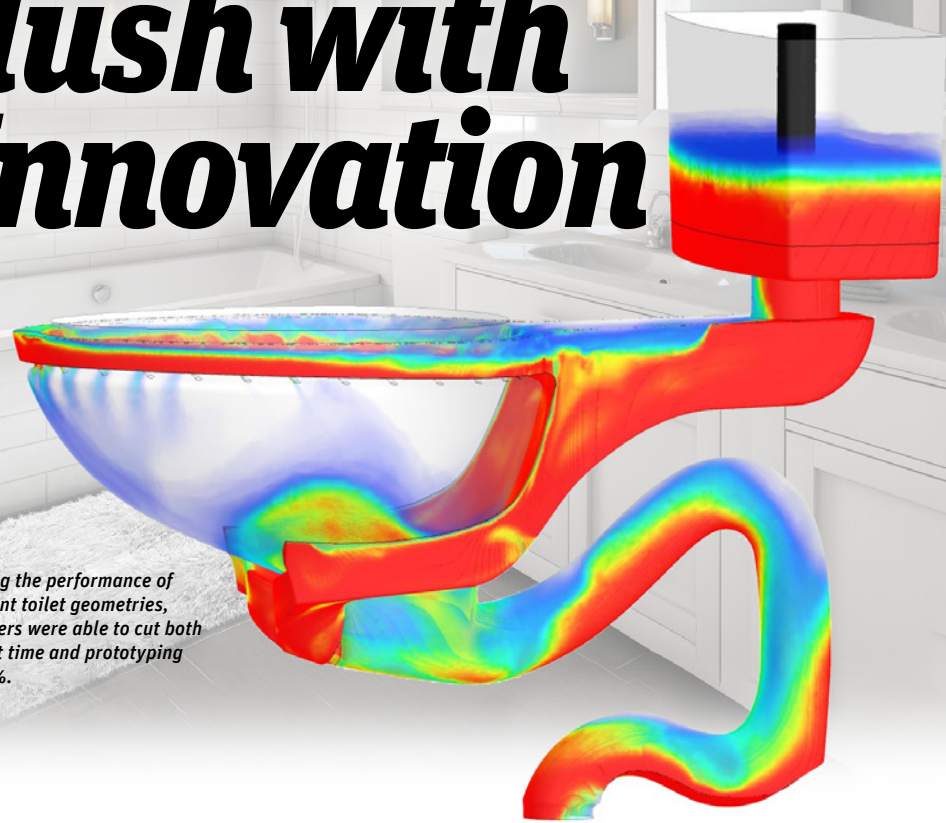

AS A GLOBAL LEADER IN BATHROOM PRODUCTS, Roca faces a significant engineering challenge: It must make incremental design changes to a mature product line to meet evolving consumer needs and new regulatory requirements. The company relies on simulation to accelerate these ongoing engineering activities — without investing in time- and cost-intensive physical testing.

By **Vicens Font**
Advanced Toilet
Technology Manager
Roca
Barcelona, Spain

To capture new sales opportunities, Roca, a worldwide leader in bathroom products, continually searches for ways to innovate and adapt its designs, increasing the diversity of its global offerings. Because the company designs plumbing solutions that include toilets, sinks, faucets, bathtubs and shower columns for 170 countries — each of which has different regulatory guidelines and consumer preferences — Roca's product line is necessarily diverse.

Innovation can be challenging for a well-established company like Roca, which has been manufacturing industry-leading bathroom products since 1917. The majority of its products are mature, time-tested designs that have maintained the same basic configuration for decades. Roca's engineers rely on ANSYS simulation to quickly and cost-effectively identify innovations that address changing regulatory requirements around water usage, deliver customized products for different regions of the world, and position the company to lead the industry with new features.



GROWING SALES VIA SIMULATION

In the U.S. and Asia, consumers are used to toilet designs based on siphon jet technology, which creates a vacuum effect in the trapway of the toilet bowl as water is released. The waste is pulled out by the water. In Europe, consumers prefer a wash-down design in which water is flushed very quickly into the bowl via a rimless design that was pioneered by Roca. The water pushes the waste out.

While Roca had optimized the low-consumption performance of its toilet designs using wash-down technology, the company wanted to reach the same level of performance via a siphonic toilet design.

This new toilet design would meet minimum water-consumption standards while also delivering maximum drainage power. However, very different physics are involved in pushing water versus pulling it.

Roca turned to the power of computational fluid dynamics (CFD) simulation via ANSYS Fluent software to understand and optimize this unfamiliar technology. To verify the accuracy of their simulations, Roca's engineers first constructed a real siphonic toilet that could be used as a calibration model to ensure the accuracy of future simulations that include physical parameters such as water pressure and flow rates. The results of the physical tests and initial simulations were strikingly similar, giving Roca's engineers the confidence to rely on ANSYS software and begin to reduce physical testing.

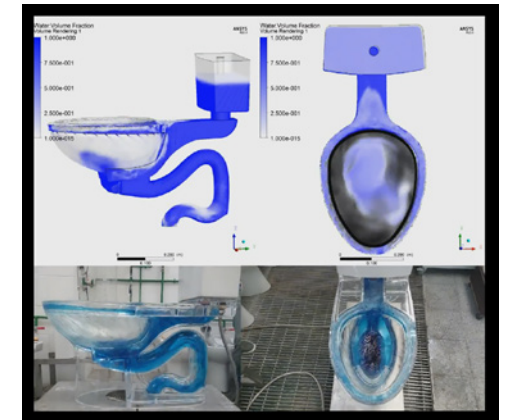

By first constructing a physical toilet model, Roca engineers were able to compare and verify the results of their early simulations — giving them the confidence they needed to eliminate some physical testing.

Over the ensuing months, Roca's engineers leveraged simulation to optimize many aspects of the new product's performance, including water distribution in the toilet's rim and jets, reaction times and refill volumes. Understanding how water flows through a toilet is extremely complicated, because every single parameter affects the final performance. Roca's CFD simulations enabled engineers to focus on the right radius, the right contour, the right tolerance range and other critical design parameters.

Roca simulated many different geometries in its efforts to optimize the new product's design. Each of these simulations required a week to prepare, run and analyze the results. If the team had

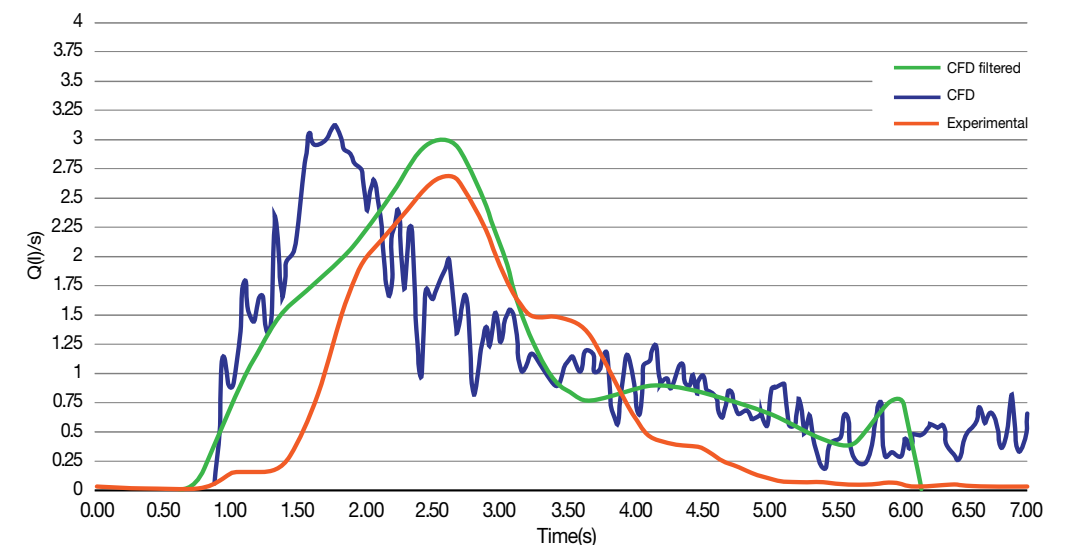

Flow rate comparison between an ANSYS simulation and real-world results from a physical model demonstrates the accuracy of simulating toilet performance via ANSYS solutions.

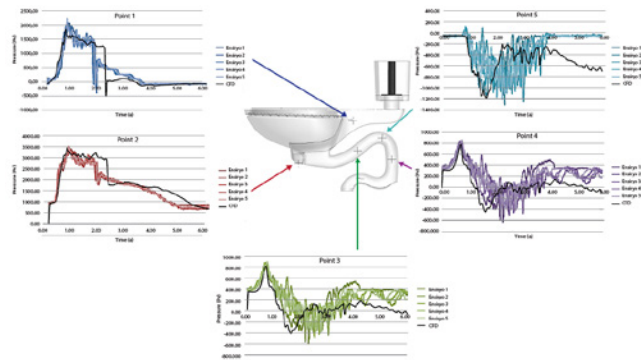

Pressure comparisons between CFD simulations and the physical toilet model — captured at different design points — proved to Roca engineers that they could rely on simulation.

example of the kinds of product customization activities Roca engineers are engaged in daily to make its offerings more attractive to customers in different markets. ANSYS simulation enables engineers to put together diverse components such as tanks, bowls, nozzles, jets and traps in a simulated environment before constructing physical prototypes of updated toilet designs.

Simulation also enables Roca engineers to modify its existing designs quickly to address changing water consumption regulations in different countries. As consumers and government regulators alike continue to press for lower and lower water levels for toilets, showers and other plumbing products, Roca’s engineers are working on innovations to maximize their products’ efficiency at these lower and lower water levels. Although more intangible, the impact of these innovations for the environment is making a difference.

FLUSHING OUT NEW IDEAS

To date, Roca’s product development team has devoted most of its simulation time to toilets, which represent one of the company’s core products. However, as Roca adds new ANSYS licenses and new users, it is turning its attention to innovations across its product line, including electronic shower toilets, faucets and shower trays.

While many of Roca’s products are mature and proven, the company is committed to differentiating itself in order to capture the rare opportunities when consumers buy bath fixtures — typically during new construction or renovation. If Roca can lead with innovation, it can capture these opportunities and continue to make best-in-class plumbing solutions.

For the Roca engineering team, that means changing the shape of nozzles and pipes, testing new flow dynamics and making other incremental changes. But it also means pioneering new product concepts. In all of these efforts, simulation enables an early look into how new bathroom fixture designs will perform under real-world conditions, allowing the product development team to be first to market with newer, and better, customer solutions. By using ANSYS simulation software, Roca’s engineers have cut the typical number of prototypes for new products by up to 66%, which results in an equivalent reduction in time and costs. **A**

“Roca’s engineers leveraged simulation to optimize many aspects of the new toilet’s performance.”



constructed physical mock-ups of these different geometries, each one would require three weeks — so, in addition to the prototype cost savings, Roca engineers were able to cut development time by two-thirds using simulation. The new design gives Roca a critical opportunity to enter new markets and increase sales revenues substantially.

PRODUCT CUSTOMIZATION: A GLOBAL CONCERN

This landmark product introduction is an extreme

Heating Up Off-Road Vehicle Cabins



By **Morteza Marivani**
 Group Research and Development Scientist
 Product Development and Group Technology Manager
 Advanced Simulation Center
 Mobile Climate Control
 Vaughan, Canada

Off-road vehicle machinery operators — like those on a construction crew — spend long hours in their equipment under a wide range of weather conditions and want to precisely adjust the temperature of the cabin. By utilizing simulation, Mobile Climate Control engineers are creating heater valves that enable occupants to have full control of cabin temperatures for maximum comfort.



“Fluent accelerated the redesigned valve’s speed to market by enabling engineers to spend minimal time on the meshing and maximum time on solving the flow problem.”

Construction crews operate year-round, often performing in extreme cold. Operators running machinery like excavators rely on custom-engineered climate control systems to keep them comfortable and protect them from the elements.

Off-road vehicles heat their passenger cabins in the same manner as commercial cars and trucks. Ethylene glycol coolant, better known as antifreeze, cools internal combustion engines and prevents damage to engine blocks. The coolant is pumped through the engine and radiator, enabling the engine to release heat.

On cold days when operators want to heat their cabin, a portion of this coolant absorbs the heat from the engine, warming it to near-boiling temperatures. The hot coolant then flows through heater core tubing, which serves as a heat exchanger between the coolant and cabin air. As a blower fan pushes air over the heater core tubing’s metal fins, the coolant’s heat is absorbed or transferred to the airstream that heats the operator’s cabin. A heater valve connected to a control knob controls the air temperature by regulating the amount of coolant that flows through the heater core. More coolant means hotter air is delivered into the cabin.

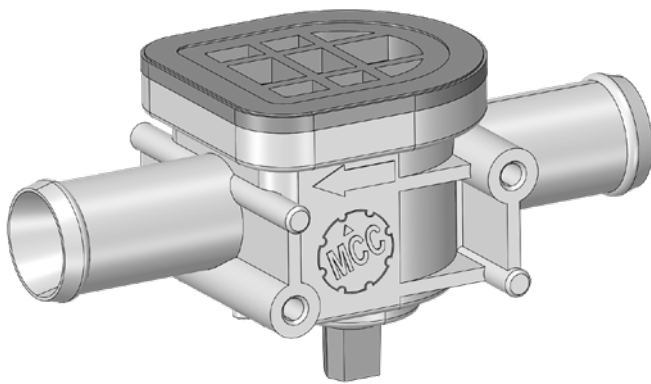

Valve model

Mobile Climate Control (MCC) applied ANSYS Fluent to simulate the pressure-driven flow through the heater valve. Mosaic poly-hexcore meshing created a high-quality volume mesh of the flow field quickly

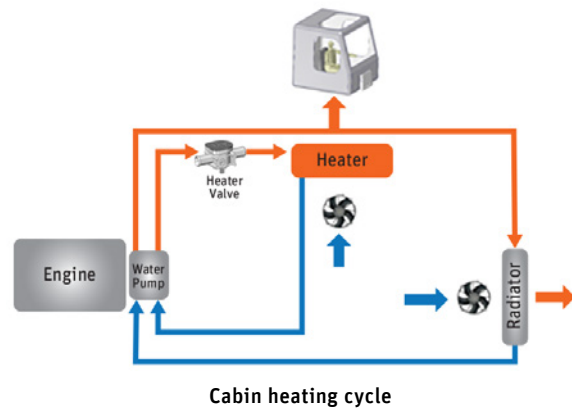

and efficiently. MCC engineers developed an optimized design for the valve geometry that maximized its ability to precisely control the volume of coolant that flows through the valve at each position of the valve’s knob to improve cabin heat control.

COOLANT FLOW THROUGH THE VALVE

The control valve’s inner core rotates 60 degrees in total between its fully closed (0) and fully opened position (60). Historically, the valve performed well at positions between 15 degrees and 45 degrees because it experienced maximum liquid flow. However, between 45 degrees and 60 degrees, the flow did not change, so fine control of heating was not possible. To address this, engineers focused on redesigning the geometry of the valve’s inner core to achieve maximum volumetric flow rates with the valve fully opened at 60 degrees.

SIMULATING THE CONTROL VALVE

MCC first used Fluent to model the original valve’s performance. Engineers imported the valve’s 3D CAD models into Fluent and used the task-based watertight geometry workflow to create a high-quality, poly-hexcore volume mesh with Mosaic meshing technology. They ultimately reduced meshing time from three hours to less than an hour to obtain acceptable mesh quality for the fidelity required.

ANSYS Fluent simulated the flow field inside the valve and provided insights on how engineers could optimize the valve’s inner core geometry to reach their goal. Engineers were then able to manually change the

“Without simulation, engineers would not have been able to observe and understand the flow pattern.”

valve’s inner core geometry to improve its performance through better control of the volumetric flow rate. The team was able to re-run the simulation, see the result, determine the amount of improvement and finalize the geometry of the inner core. If engineers conduct this process through trial and error using a physical prototype, it would be very expensive and time-consuming.

The simulation results revealed the heater valve’s flow rate curve (volume of liquid per unit time) in its different positions – from fully open to fully closed – in five-degree increments. This allowed engineers to



extract the volumetric flow rate amount at different valve angles for any specified inlet pressure for the valve and compare it with actual valve performance in the field.

Without simulation, engineers would not have been able to observe and understand the flow pattern through the valve’s inner core and they would not have been able to improve the core’s geometry to reach their goal.

Fluent accelerated the redesigned valve’s path to market by enabling engineers to spend minimal time on the meshing and maximum time on solving the flow problem. The speed and ease for creating this excellent mesh generated quick results and allowed more designs to be evaluated.

MCC optimized the valve’s design to improve the overall performance of the heating system. Operators now have precise control for adjusting the cabin’s interior temperature. ⚠️

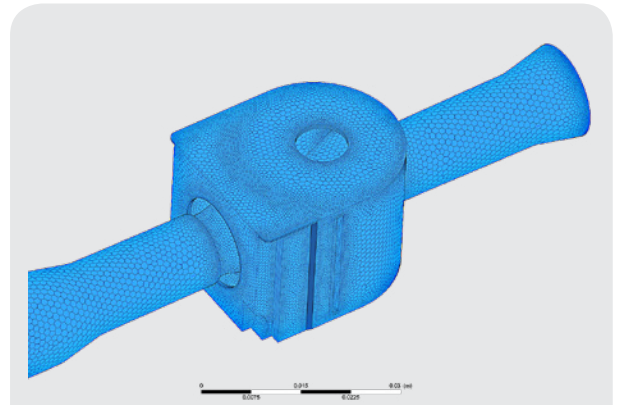

Overall volume mesh for CFD simulation

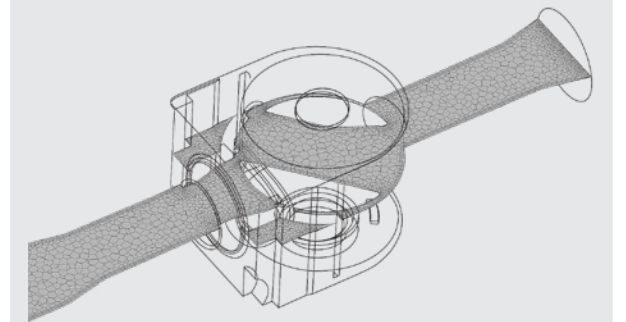

Cross section of created volume mesh

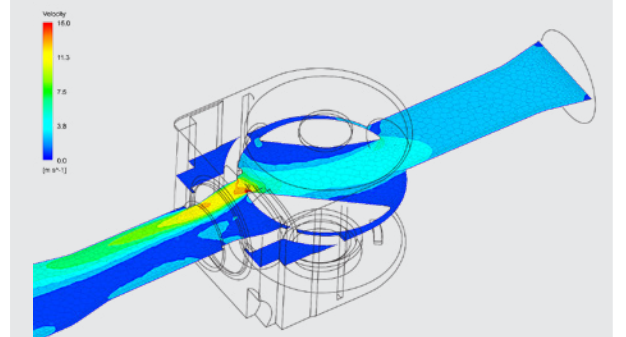

Velocity contour plot of valve at partially opened position

Energizing Generator Designs

By **Itsaso Auzmendi Murua**
Thermal Research Engineer
INDAR
Beasain, Spain

Generators serve as the heart of hydroelectric power plants and must be accurately designed to optimize energy output and prevent excessive temperatures that cause energy losses and shorten the machine's life. Leveraging ANSYS simulation and an improved workflow, INDAR engineers improve generator design accuracy and accelerate all stages of their simulation. This allows them to meet tight delivery deadlines and significantly scale generator production.

Providing the world's largest source of renewable energy generation, hydropower delivers clean, affordable and reliable energy. Among renewable energy sources, hydropower is only second to wind in offering the lowest carbon emissions per kilowatt hour.

Generators are the heart of a hydropower plant's electricity production process and must reliably optimize energy output.

Excessive heat within the generator, known as hot spots, can lead to energy losses or even shorten the life of the machine.

Established in 1940, INDAR, an Ingeteam company, is a leading power conversion partner for its customers: energy generation (generators for wind,

◀ An ANSYS Fluent simulation determined the temperature profile of the active parts of a salient pole generator.

 ANSYS Fluent Mosaic Technology
[ansys.com/mosaic-meshing](https://www.ansys.com/mosaic-meshing)

hydro, internal combustion, steam and gas), marine electric propulsion (motors and generators), industrial drives (motors) and submersible water pumping (motor pump sets). Producing physical prototypes of many of the highly complex hydroelectric generators of enormous size manufactured by INDAR is too costly and impractical. Instead, engineers rely on simulation and in-house analytical tools to produce a version of the generator to satisfy tight delivery timelines. INDAR leverages ANSYS Mechanical, ANSYS Maxwell and ANSYS Fluent simulations to create designs that ensure the performance of these machines. Many of INDAR's hydropower generators are nonstandard designs that must be customized according to each customer's requirements. This level of customization requires flexible, comprehensive and accurate engineering simulation.

The team's recent adoption of ANSYS Mosaic technology to enhance the Fluent meshing workflow has greatly accelerated all stages of the team's simulation work. Automation has cut hands-on development time because preprocessing time has been reduced from six to eight days to four hours, and solving time has been slashed by 30%. This greatly speeds up production as each design variation requires only one day to be analyzed instead of more than a week.

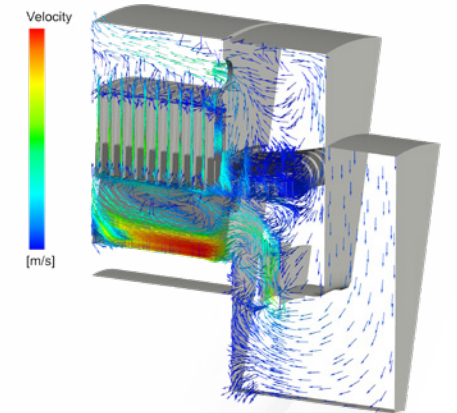

ANSYS Fluent simulation of the velocity profile of a generator helps to ensure adequate cooling airflow.

“INDAR engineers can meet performance targets in less time so they can explore a larger number of options to further improve the generator.”

GENERATING THE DESIGN

INDAR engineers use ANSYS Maxwell simulations to verify and optimize the electromagnetic design of the electric generator. The team begins the process with RMxpert — an analytical sizing tool included within Maxwell — to parameterize many dimensions of the generator and run hundreds of what-if scenarios, examining many operating conditions in a matter of seconds to form a preliminary design.

Engineers then use ANSYS Maxwell to simulate the best candidate configurations from the preliminary design for electromagnetic behavior. This guarantees that the generator will perform optimally. The team reduced electromagnetic design time from three days to one by using ANSYS electromagnetic field technology.

To ensure that the machine operates reliably throughout its service life, engineers next must validate the generator's cooling system to prevent the machine from reaching unacceptably high temperatures. Optimization of the cooling circuit helps to improve the efficiency of the generator by reducing mechanical and cooling losses. To demonstrate that the heat can be released without affecting the behavior of the generator, INDAR engineers use multiphysics simulations by applying the heat-induced electromagnetic losses calculated by Maxwell, as well as inlet temperatures and thermal boundary conditions in ANSYS Fluent, to run a thermal analysis.

To obtain the velocity fields and thermal profiles, engineers employ ANSYS Fluent simulation. Velocity fields are required to ensure adequate air flow throughout the entire generator to cool the heat generated by the electromagnetic parts. They also want to prove there are no stagnation points where the air does not flow or any spot where there are excessive velocities, which can cause large pressure drops or other issues. Engineers also review thermal maps to identify potential hot spots to confirm that the

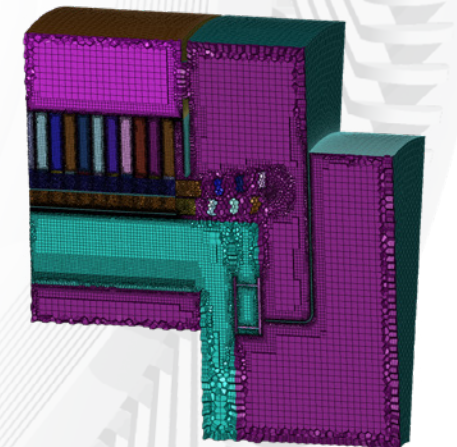

Mosaic-enabled poly-hexcore mesh

“Preprocessing time has been reduced from six to eight days to four hours and solving time has been slashed by 30%.”

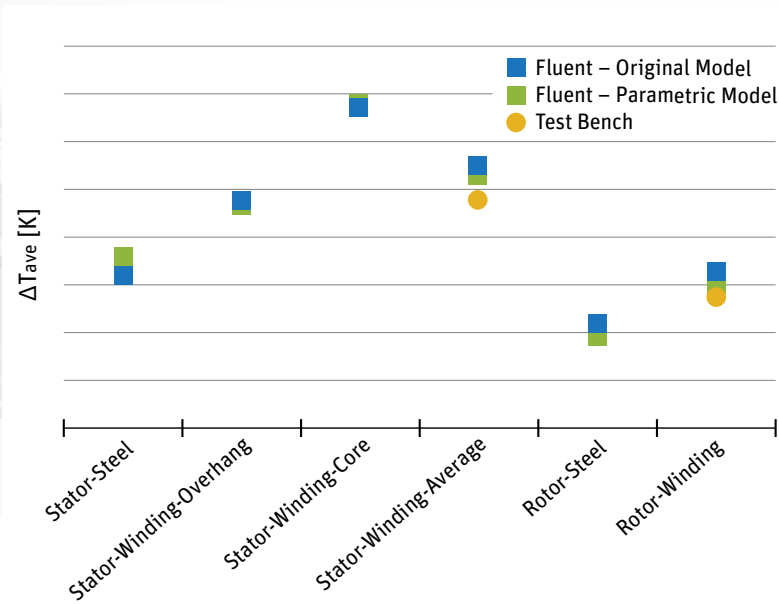

Temperatures obtained using the old workflow (starting from design drawing). The new workflow (parametrized model) and the measurements from the test bench were in agreement.

designed cooling flows can keep the machine’s parts below the established temperature limits.

INDAR engineers use the simulations they perform in Maxwell and Fluent along with their in-house analytical tools to study generator designs within minutes.

FAST AND AUTOMATED MESHING

Meshing generators of such dimensions is challenging because of the difference in scale. The mesh must accommodate small air gaps between the rotor and stator (measuring a few millimeters) where accuracy is paramount, as well as the much larger overall length and diameter of the generator and cooling system. Some of these dimensions can reach 4.5 meters.

The need to simultaneously solve turbulence and energy equations requires creation of a conformal mesh between the fluid and the solid parts.

Engineers must also accurately capture the heat transfer in the boundary layer. This requires a mesh with an inflation layer, which adds more levels of complexity when building the mesh.

The ANSYS Fluent simulation is expedited by a task-based workflow and Mosaic-enabled poly-hexcore meshing technology. Engineers employ ANSYS SpaceClaim to process the geometry created in Maxwell and CAD for CFD simulation, then mesh the generator. INDAR engineers have also developed a parametric geometry model that allows them to build their 3D generator geometries within minutes thanks to ANSYS SpaceClaim, by just filling in the generator dimensional specifications in a table

within ANSYS Workbench. This workflow greatly accelerates all stages of the simulation from meshing to solution. The team can reduce preprocessing time from six to eight days to less than four hours and generate an answer to a specific design question using 30% less solver time.

Mosaic meshing technology yields improved accuracy and higher-quality meshes with 15% fewer cells and requires half the time to solve when compared to previous methods. Prior to leveraging Mosaic, engineering



teams applied traditional mesh topologies like tetrahedral elements. These meshes excelled in flexibility and process robustness but were less than optimal in solving for performance and accuracy. Automation was possible, but engineers needed to write, understand and maintain scripts, which required a specific expertise. In addition, to explore a slightly different scenario, a standard script had to be modified using a trial-and-error approach. These steps have been largely eliminated through the new meshing workflow that allows the team to create customized templates in a quicker and automated way.

Mosaic technology automates many of the standard and repetitive meshing tasks to greatly reduce the engineer’s hands-on development time, improve productivity and speed up the time to create high-quality CFD mesh. Automation has been a real game changer as it empowers engineers at any level of experience to quickly develop designs because Mosaic does much of the work. The engineer defines the most appropriate inputs for the type of physics required to get the desired mesh at a fraction of the time that it formerly required.

Mosaic reduces the overall number of cells, and the poly-hexcore cells in the bulk regions reduce the number of equations, leading to a faster solve time. Poly-hexcore is more efficient than the tetrahedral meshing the team previously used.

The team can increase meshing speed even more by using parallel processing so that meshing creation can be accelerated up to 10 times by applying multiple cores during the mesh generation process.

INDAR engineers have verified the accuracy of the ANSYS thermal simulations by comparing the results to their test-bench air flow, mechanical loss and temperature measurements. The results confirm that the simulation models predict the measurements with great accuracy.

As a result, INDAR engineers can meet performance targets in less time so they can explore a larger number of options to further improve the generator.

INDAR uses ANSYS simulation to model many of its generator types, perform modifications to existing designs and study the influence of new designs. Engineers then use the results to feed internal analytical programs, which provide generator design specifications within minutes.

Delivering a fast, trusted workflow, ANSYS simulations significantly reduce research and development time while optimizing energy output. This enables INDAR to scale production and speed the path to market to further support the world’s hydropower needs. 

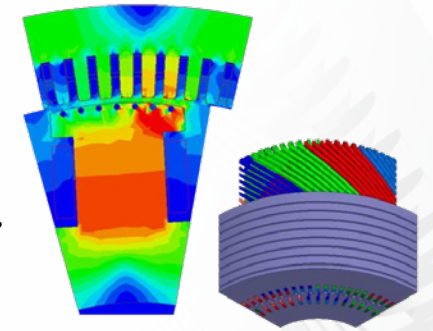

ANSYS Maxwell simulation

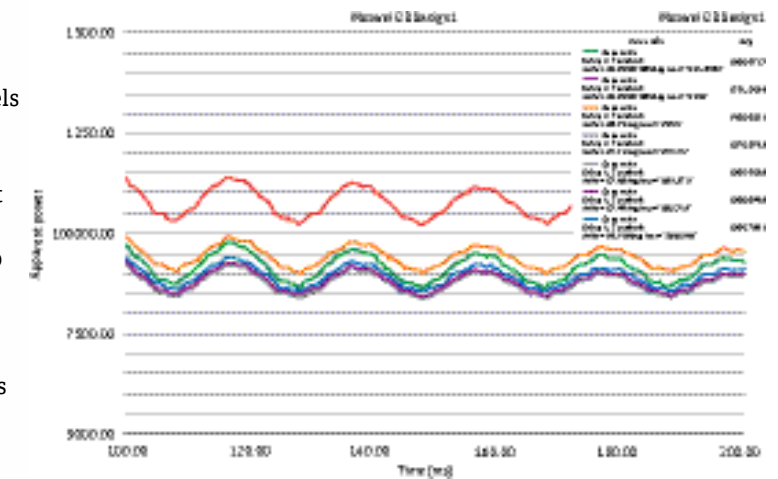

ANSYS Maxwell simulation for apparent power using the new workflow

With production plants in Beasain & Segorbe (Spain), Milwaukee (U.S.A.) and Mexico D.F., INDAR, an Ingeteam company, delivers one-stop solutions for those sectors backed by strong R&D and engineering capabilities. By addressing the challenges that their customers face within different sectors, INDAR provides sustainable and efficient innovation. Its net sales totaled EUR 217 million with 800 employees. As of 2018, INDAR had 39 GW of installed power around the world.

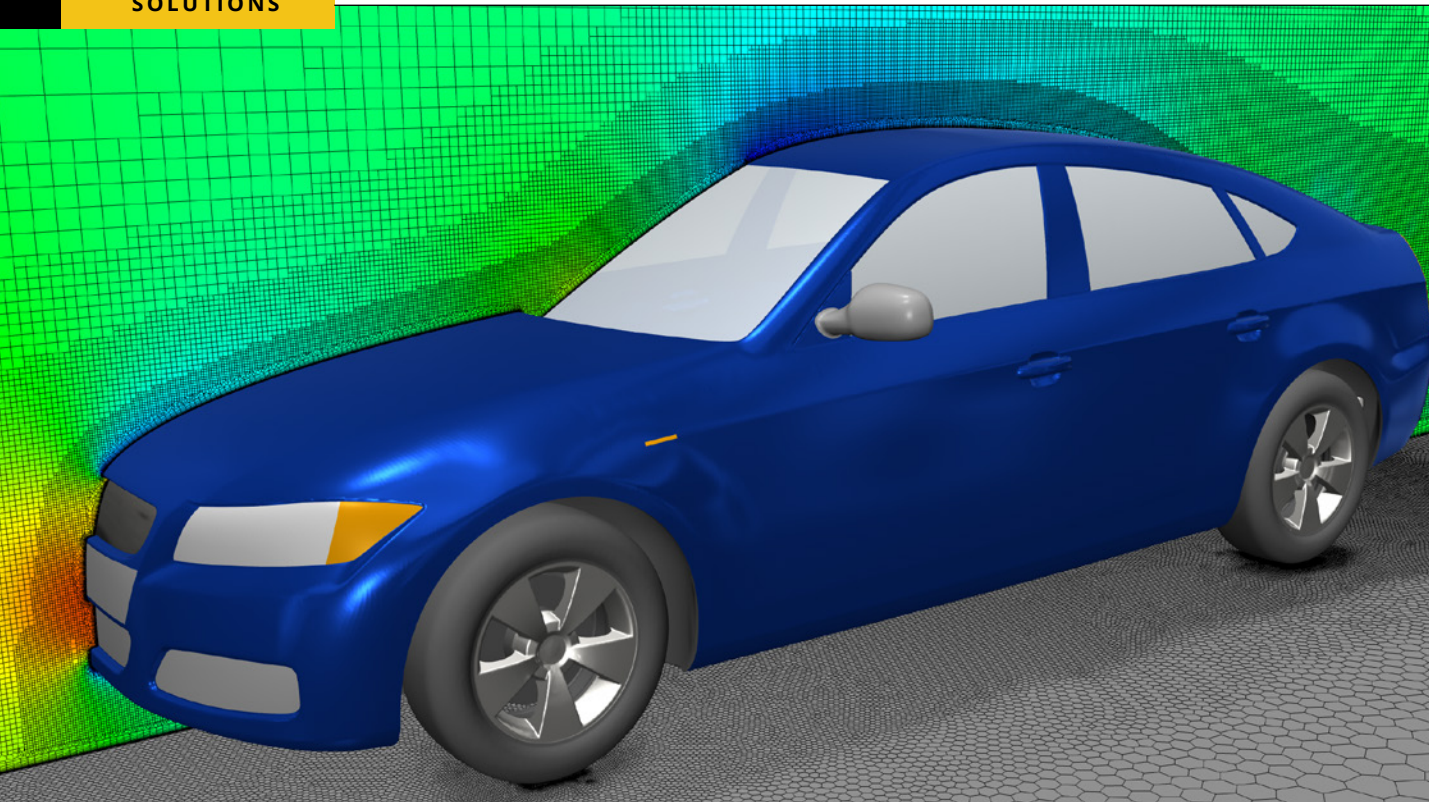

Smother Transitions with Mosaic Meshing

Transitioning between various types of mesh elements in complex geometries and flow regimes has long been a major CFD simulation challenge. ANSYS Mosaic technology automatically and conformally connects any type of mesh to any other type with general polyhedral elements. The result is faster simulations with greater solution accuracy while using less RAM.

By **Harsh Vardhan**
Director of Software
Development – Meshing
ANSYS

in resolving different geometries and flow features. But transitioning between varying types of elements poses significant challenges. The transition zone has typically relied on non-conformal interfaces or on pyramids/tetrahedra, but these could come with issues regarding solver performance, mesh quality and excessive cell count.

ANSYS has developed the new, patent-pending Mosaic technology, which conformally connects any type of mesh to any other type of mesh, to eliminate the need to compromise. This ensures that the best

Accuracy and performance are two of the most critical concerns in computational fluid dynamics (CFD) simulation, and both are highly dependent on the characteristics of the mesh. To realize the power of simulation in early design stages and test many variant designs, the meshing process should be automated. For an automated meshing process, diverse types of elements are needed to deliver optimal performance

in resolving different geometries and flow features. But transitioning between varying types of elements poses significant challenges. The transition zone has typically relied on non-conformal interfaces or on pyramids/tetrahedra, but these could come with issues regarding solver performance, mesh quality and excessive cell count.



“Mosaic technology ensures that the best type of mesh element is used in every section of the geometry for optimal results.”

type of mesh element is used in every section of the geometry for optimal results.

Mosaic technology automatically connects different types of meshes with general polyhedral elements. Poly-hexcore, the first application of Mosaic technology, fills the bulk region with octree hexes, keeps a high-quality, layered poly-prism mesh in

the boundary layer and conformally connects these two meshes with high-quality general polyhedral elements. The resulting simulation is faster with greater solution accuracy while using less RAM.

CASE STUDY: USING MOSAIC MESHING TO MODEL AUTOMOBILE AERODYNAMICS

When designing a new automobile, the aerodynamics of the vehicle are of major importance. To understand fundamental flow phenomena to great effect, and to openly share/publish/compare simulation and physical testing practices and results, researchers at the Institute of Aerodynamics and Fluid Mechanics at Technical University of Munich (TUM) proposed a customizable DrivAer model in 2011. The DrivAer

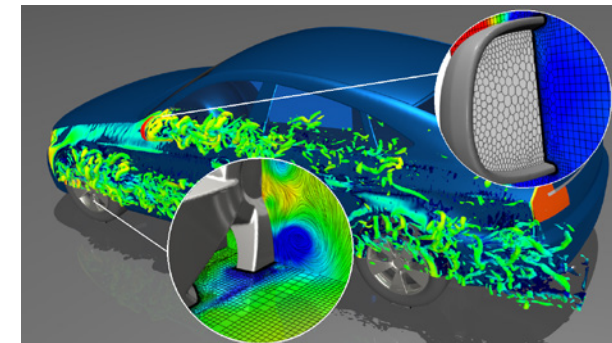

Detailed aerodynamics SBES simulation of DrivAer model shows details of Mosaic meshing and turbulent airflow around the wheel hub and the external side mirror.

body, with options for 18 different parameters (for example, fastback, estate-back or notchback rear-end configurations; a detailed underbody or a smooth one; with mirrors or without, etc.) enables engineers to investigate many more detailed and complex aerodynamic phenomena and share their findings widely. The DrivAer geometry is available for free download

to interested parties and is being used extensively throughout the automotive industry.

MESHING THE DRIVAER MODEL

Surface Meshing

The surface mesh was created with isotropic triangles using advancing-front meshing technology. The sizing definition is very simple and allows automatic refinement of the mesh in areas of high curvature, small features and close proximity to surfaces. Users can add specific sizing as required. Surface mesh refinement is also applied on surfaces where wake volumetric refinement has been specified using a series of scaled offset shapes from the car geometry.

A NEW PARADIGM IN TURBULENCE MODELING

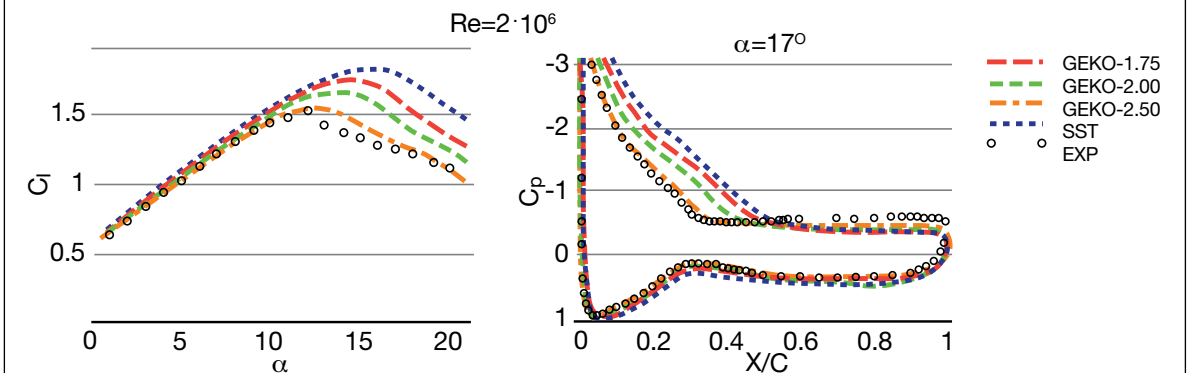

The GEKO (generalized k-omega) turbulence model is suitable for all flow applications. It has the flexibility to tailor turbulence models to specific applications. In this example, GEKO's free and tuneable parameters were adjusted to match simulation to the physical measurements.

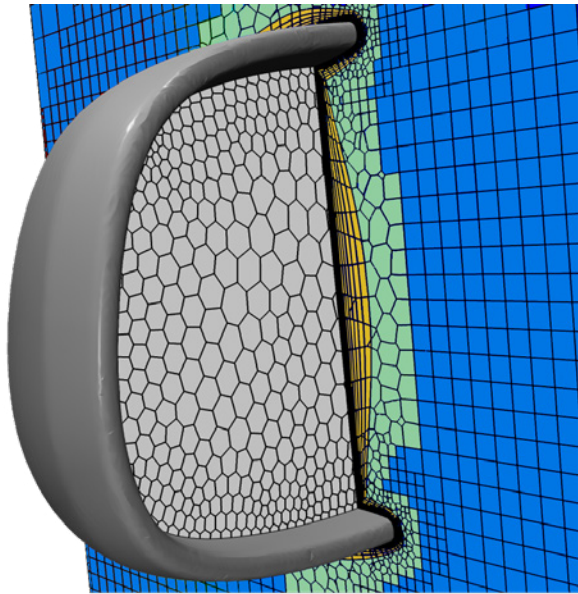

- POLY-PRISM**
 - High-quality
 - Significantly fewer cells than tri-prism
- HEX-CORE**
 - High-quality
 - Fast solve times
- NEW: MOSIAC TECHNOLOGY**
 - Conformally connects poly-prisms to hexcore

Cross section showing poly-hexcore mesh around a side mirror

Volume Meshing Using Mosaic

Engineers applied Mosaic meshing to the volume, including the separate, conformal volume regions inside the wheel hubs. This allows the solver to apply the correct rotational body forces in the simulation. In such simulations, accurate prediction of boundary layer separation is crucial, so the resolution of the mesh close to car surfaces with extruded prisms is important for accuracy. For this reason, 20 highly anisotropic poly-prism elements (y+ approximately equal to 1) were used to capture the boundary layer accurately with smooth growth into the bulk mesh. Away from walls, perfect hex elements were automatically generated to efficiently fill the volume and capture gradients and vorticity in off-body flow. To connect the prism and the hex elements, a polyhedral “transition layer” was generated by Mosaic to give high quality and low mesh count transition between the two.

For this external aerodynamics simulation, engineers generated an

extremely high-quality mesh with 63 million elements. This provides a huge saving in number of elements when compared to the traditional hexcore with triangle-based prisms and tetrahedral transition layer, which consisted of 106 million elements. The Mosaic poly-hexcore mesh also utilized parallel meshing and took less than 16 minutes to generate on 32 cores requiring less than 115 GB of RAM. ANSYS Fluent users can mesh on distributed memory HPC clusters directly from the software without need for additional HPC licenses.

CFD Simulation

Fluent users embracing the new Mosaic technology are reporting up to 2-times solver speedup with similar or better levels of accuracy than was observed using a purely polyhedral mesh approach. External aerodynamics innovations in the solver are also leading to better predictions than ever before using new proprietary turbulence-modeling capabilities. The GEKO (generalized k-omega) model is a tunable RANS model, which allows safe modification of parameter sets to better match experimental data for a wide range of turbulence phenomena, including separation and vorticity. Stress-blended eddy simulation (SBES), on the other hand, is an enhanced scale-resolving unsteady turbulence model that gives unparalleled resolution of fine turbulence structures within a hybrid RANS-LES framework. Both innovative models combine well with Mosaic meshing technology to deliver a leap in productivity and accuracy for external aerodynamics simulation.

Mosaic mesh-connecting technology has the potential to deliver exciting new combinations of meshing elements that will help meet the challenge of increasing complexity and accuracy requirements for years to come. Since Mosaic is an enabling technology, you can expect to see it appearing in other ANSYS meshing workflows soon. ⚠️

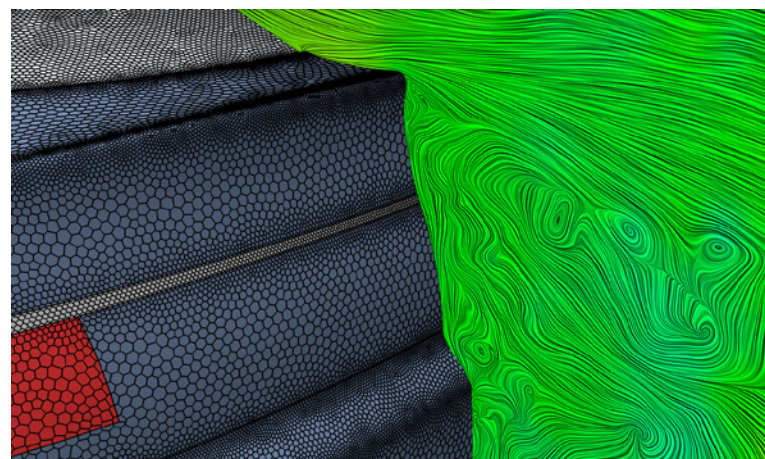

Mosaic-enabled mesh was used to capture details of turbulent flow around the rear of this car.

Early Simulation Avoids Chip Burn

By **Yadong Wang**
Staff Engineer
Qualcomm
San Diego, U.S.A.

Thermal constrained performance is a challenge for GPU designs. Using ANSYS PowerArtist to perform a unique differential energy analysis early in the chip design process (during RTL design), Qualcomm engineers were able to identify and fix redundant switching in their GPU to improve the power efficiency of key design blocks by 10%.

Smartphone and tablet manufacturers are continually changing their designs, searching for advantages over competitors’ offerings. Each new model can do more, quicker, with longer battery life. At the same time, applications and background functions consume increasingly larger amounts of power.

Engineers at Qualcomm, a global leader in mobile technologies, are always exploring ways to improve the performance of semiconductor components in mobile devices. The graphics processing unit (GPU), in particular, is a critical component for consumer applications such as gaming. Imagine a consumer playing a video game on a phone. The faster the GPU and the longer the game goes on, the more the GPU

IO	Internal Energy	Switching Energy	Description
1	→	→	• No extra toggles; energy is efficient
2	▲	→	• D pin has no extra toggles during bubbles • Extra toggles on clock pin when data stable
3	→	▲	• Extra data toggles on D/Q pins when clock is off
4	▲	▲	• Extra toggles on both D/Q pins and clock pin

Methodical approach pinpoints redundant register pin toggles by investigating four scenarios.

RTL-Based Power Flow

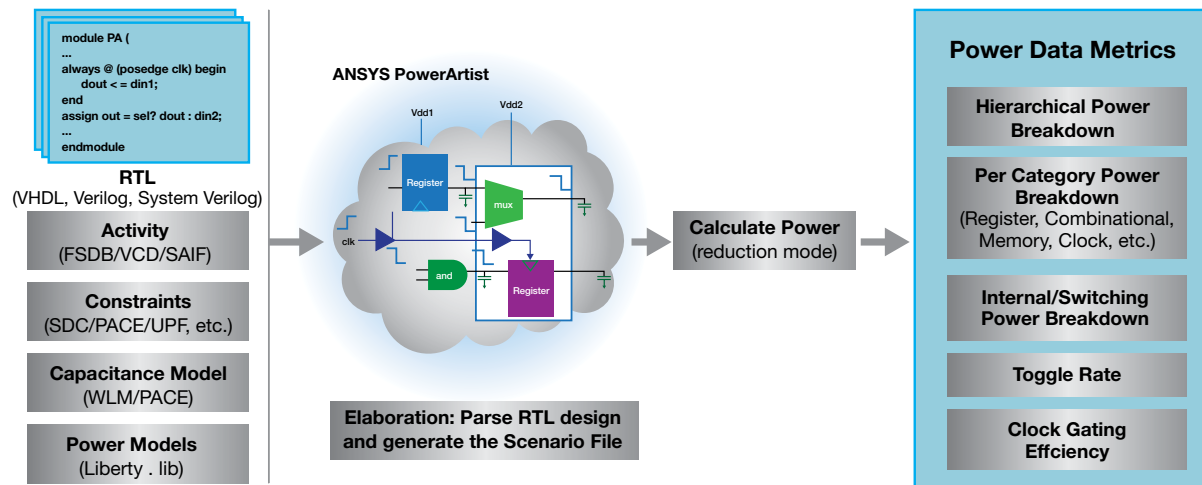

RTL-based power efficiency enables early and reliable design decisions.



“Qualcomm’s differential energy analysis early in the design flow using ANSYS PowerArtist delivers 10% higher performance per watt.”

dissipates power, causing the temperature of the phone to increase. At some point, the phone automatically reduces the clock speed (within reasonable limits) to cool itself by reducing power dissipation. But this causes the game to slow down. While annoying, these slowdowns are part of the phone’s design. Such thermally constrained performance is becoming a key performance indicator in GPU design.

Instead of just living with these slowdowns, Qualcomm is doing something about them. Using ANSYS PowerArtist simulations to perform differential energy analysis of GPUs early in the development process, at the register transfer level (RTL) when the microarchitecture is being determined, optimizes the power efficiency of GPUs and keeps device temperature down.

EARLY RTL POWER ANALYSIS

Qualcomm selected ANSYS PowerArtist for power analysis and reduction at RTL because of its realistic approach to evaluating power. For example, traditional power profiling only samples design activity over a few microseconds, which is too short a time to provide a realistic snapshot. Instead, ANSYS PowerArtist analyzes real-world use cases (like a high-definition video frame) to create

Premise: For Same Test, Same Workloads

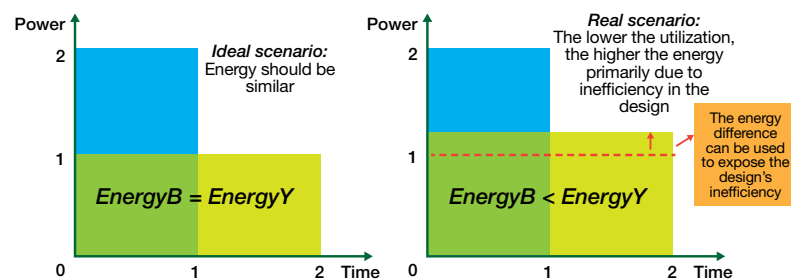

Higher energy for slower vectors exposes redundant activity.

power profiles within a few hours, which is orders of magnitude faster than standard approaches. Beyond power profiles, it allows engineers to budget power for the different parts of the design reliably at RTL through unique modeling of design implementation effects such as clock trees. It supports power efficiency analysis through quantifiable metrics, what-if power trend analysis, power-debugging for tracing problems to their roots, and power regressions, which are useful when a seemingly small fix suddenly causes a power surge elsewhere.

DIFFERENTIAL ENERGY ANALYSIS

In their quest for a power-optimized design, the Qualcomm design team first minimized power leakage through process selection and power islands. Next, they focused on minimizing redundant switching activity to find dynamic power savings. They took an ingenious approach for this task: Instead of looking directly for redundant switching in the GPUs – a time-consuming, tedious process – they compared two versions of the same GPU by simulating them running at different speeds. Slower speeds were simulated by adding latencies to mimic starvation or stalls, for example. If the original design was optimally clock-gated, the number of nets switching should be the same for both runs, and the total energy for both runs should



“ANSYS PowerArtist analyzes real-world use cases within a few hours, which is orders of magnitude faster than standard approaches.”

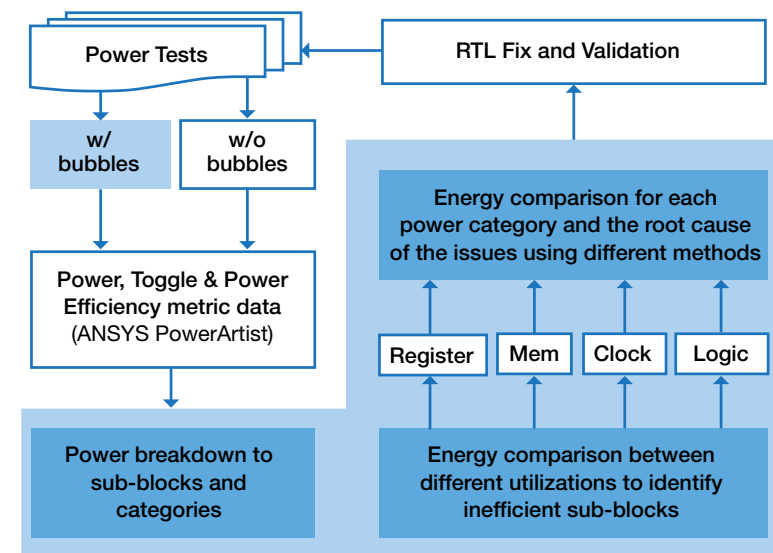

A unique methodology for differential energy and power analysis

be the same. However, if there were any gating inefficiencies in the original design, redundant switching in the design would be active over a longer period in the slower run, and therefore the integrated energy in that run would be higher than in the original run.

LOCATING REDUNDANT ACTIVITY

After discovering that the integrated energy in the slower run was higher, indicating the presence of gating inefficiencies, Qualcomm engineers took the analysis a step further in terms of dynamic power analysis. Noting that PowerArtist separates (at each level) switching and internal energy contributions, in addition to total energy, they were able to pinpoint the locations of redundant activity.

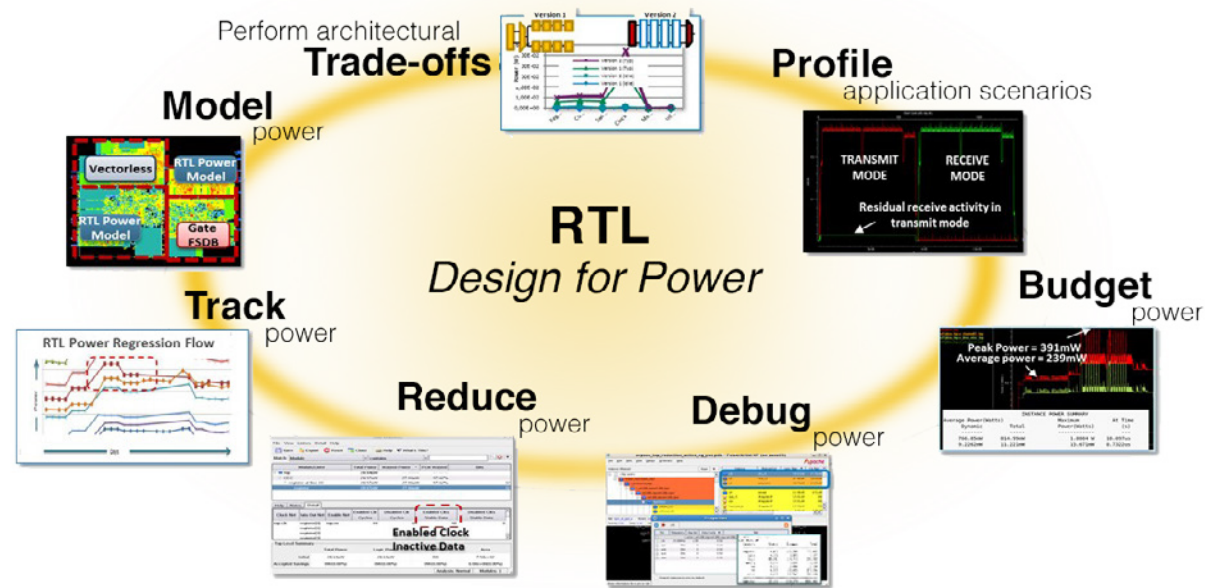

Seven steps to low-power RTL design using PowerArtist

“Differential energy analysis early in the development process, at the register transfer level (RTL), can optimize the efficiency of GPUs and keep mobile device temperature down.”

Internal energy is the energy dissipated inside gates such as registers, whereas switching energy is the energy associated with the interconnect between gates. Redundant data input or output toggles on a register will, in the slower simulation run, cause an increase in both switching and internal energy, whereas redundant toggles on the clock input will increase only internal energy. There are four possible switching scenarios that help to pinpoint redundancies.

If there is no difference in either internal or switching components, optimization is ideal. In the other cases, it is easy to determine where there must be redundant activity. These include:

1. Extra toggles on the clock pin when data is stable
2. Extra toggles on D/Q pins when the clock is off
3. Extra toggles on both the D/Q pins and the clock pin

A MAJOR EFFICIENCY GAIN

Using this novel differential energy analysis methodology, Qualcomm engineers drilled down to find candidate blocks for more detailed analysis, including individual registers where fixes could have a big impact. Making these initial fixes helped reduce dynamic power consumption by 10%. This figure is significant for a company and an industry that is (and has been for years) incredibly focused on power reduction and squeezing inefficiencies out wherever possible. This increased efficiency came from register toggle optimization early in the design process, at the RTL stage. Similar analyses will be conducted to look for further improvements in the clock tree, memories and combinational logic. Qualcomm’s successes with power efficiency through improvements in their GPU power and performance illustrates the value of early RTL power analysis using ANSYS PowerArtist. 

Powering the Cloud-Based HPC Revolution

By Navin Budhiraja, Vice President and General Manager – Cloud and Platform, ANSYS

Engineers want access to high-performance computing when and where they need it. They do not want to wade through complicated sign-up processes, difficult installations, or complex settings and choices. Engineers want a solution that disrupts the status quo, enabling them to expedite their product design and development in a simple, no-hassle way with HPC cloud computing and next-generation capabilities.

 Try ANSYS Cloud with a Free Trial
[ansys.com/cloud-trial](https://www.ansys.com/cloud-trial)

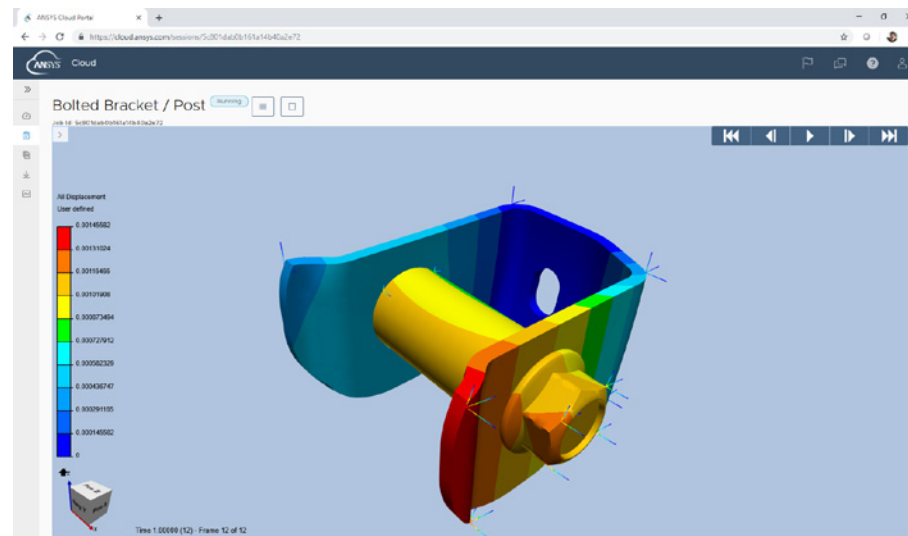

“ANSYS Cloud allows engineers to model and develop their products faster than ever and to expedite the path to market.”

The budgeting, procurement and maintenance of on-premise HPC have shifted simulation engineers increasingly toward cloud computing to conduct their complex modeling and accelerate their product design and development. In 2011, just 13% of HPC sites leveraged the cloud, later ballooning to 64% in 2018. [1]

Cloud computing’s growth shows no signs of slowing down. By 2022, 28% of spending within enterprise IT markets will be cloud-based, an increase from 19% last year. [2] This growth, largely spurred by companies that are turning to software as a service (SaaS), may contribute 75% of total cloud workloads and compute instances by 2021. [3] Instead of purchasing or upgrading their own servers, companies are turning to the cloud to overcome limited compute resources, accelerate innovation and reduce time-to-market.

Why is this happening? Generally, every two to three years, IT organizations decide whether to upgrade their company’s capital resources around HPC systems to add more cores, change from one set of chips to another or advance to the most recent technology. These organizations have the budget to make changes, but they are looking to dodge big investments and are seeking operating efficiencies and bottom-line savings in the cloud. They can then shift costs from capital expenses to operating expenses and preserve their cash. Additionally, the cloud provides more business agility so that companies can scale up or down and only pay for what is used.

Recognizing that the cloud is not a one-size-fits-all proposition, ANSYS enables customers to choose from multiple cloud deployment solutions that meet and exceed the HPC challenges of today and tomorrow. Most recently, ANSYS launched ANSYS Cloud, which makes HPC extremely easy to access and use. It has been integrated into ANSYS Mechanical and ANSYS Fluent, so engineers do not have to leave the ANSYS environment to access unlimited, on-demand compute power. Optimized specifically for ANSYS solvers and backed by the ANSYS Customer Excellence support team, ANSYS Cloud delivers simulation throughput typically reserved for large enterprises. By choosing from a set of preconfigured HPC arrangements, engineers can get results quickly.

BENEFITS OF CLOUD COMPUTING FOR SIMULATION

Faster processing and design flexibility. Leveraging the cloud unlocks an entirely new spectrum of productivity for engineers, reducing the time it takes to get their simulation results and eliminating key limiting factors that could compromise product design. According to an internal study, 90% of businesses that run simulations are forced to make modeling concessions by reducing the size of their meshes or simplifying the physics models so they can be completed in an overnight run to meet demanding schedules.

Utilizing the cloud removes these time and resource restraints. Engineers can create and analyze larger, more complex models to gain more insight into the performance of their design. Or, through parametric optimization, they can automatically assess numerous design permutations to identify an optimum design.

Burst capacity. It may not be practical for small and medium-sized companies to build an on-premise HPC system with maximum capacity, as they may lack the on-premise HPC expertise to configure and manage it. Also, it may not be economical if their simulation demand is variable. Larger engineering organizations already equipped with on-premise HPC may perform the bulk of their simulation in-house to satisfy their steady-state usage, but demand may exceed resources, delaying the team’s simulation processing. For both cases, cloud-based HPC empowers organizations to burst to the cloud when they need extra capability, paying only for what they need.

A LOOK INSIDE TRADITIONAL CLOUD DEPLOYMENTS

Cloud-based HPC offers many benefits, but it has its hurdles, particularly if an engineering organization is directly managing its own public cloud environment. They must work with a public cloud provider, create an account and install software to run on the cloud provider’s hardware. Next, they must start a software license server in the cloud, or have the cloud provider tunnel through their firewall to access their on-premise license server. Finally, companies face the challenging responsibility of selecting the best hardware options for running simulations. Public cloud providers have a wide array of hardware options. Simulation analysts must have some HPC expertise to select the appropriate virtual machines, available cores and RAM per machine, along with storage and interprocess communication to run their simulations efficiently. A poorly configured cloud environment can waste time and money, both of which are better spent on engineering tomorrow’s products and focusing on core business objectives.

What if these challenges could be eliminated? What if HPC could be as easy as running on your desktop? Enter ANSYS Cloud.

INSIDE ANSYS CLOUD

ANSYS Cloud follows in the wake of skyrocketing cloud adoption in the ANSYS customer base. According to internal estimates, ANSYS product usage within third-party cloud providers increased by 90% during the first half of 2018.

ANSYS Cloud was created specifically for ANSYS users. Engineers can instantly access on-demand, cloud-based HPC resources from within ANSYS Mechanical or ANSYS Fluent on their desktops (ANSYS Electronics Desktop will be supported in 2019 R2), eliminating the burden

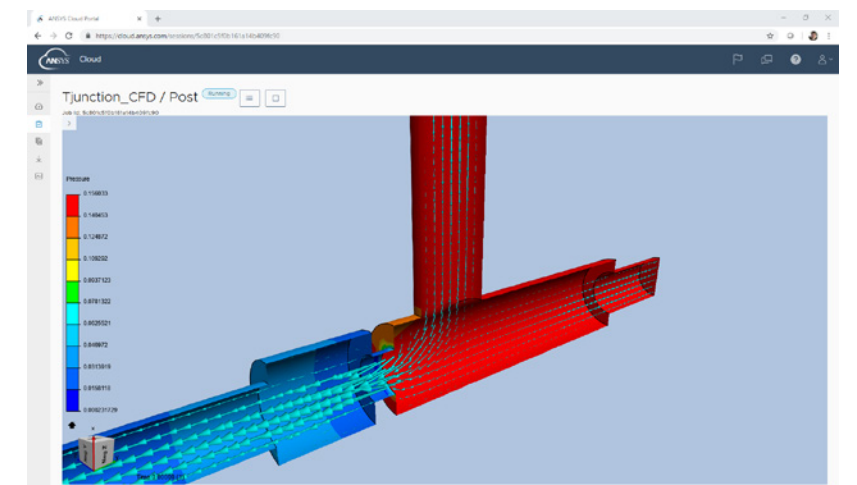

“ANSYS Cloud shaves months off design cycles and speeds market launch of smart products.”

of configuring their cloud environment, installing licenses or engaging another cloud provider. ANSYS also manages all aspects of operating and maintaining the service within the cloud.

Consistent with business models of public cloud providers, ANSYS Cloud is based on a pay-per-use licensing model to provide maximum flexibility. Companies pay only for what they use, so they can efficiently meet fluctuating demands and accommodate high usage periods associated with critical new projects.

ANSYS Cloud also shaves months off design cycles and speeds market launch of smart products. It delivers virtually unlimited cloud compute resources, so engineers can run larger, more complex and more accurate high-fidelity simulations faster. They gain additional insights and replicate real-world performance of their products with the highest degree of accuracy.

“High-efficiency equipment is critical for improving plant performance in the oil and gas industry,” said Luis Baikauskas, process engineer at Hytech Ingenieria. “ANSYS Cloud enables Hytech Ingenieria to calculate large and completed geometries within hours, instead of days or weeks, resulting in significant time savings.” Engineers can evaluate more design variations and find their optimal designs.

Designed for maximum security, ANSYS Cloud incorporates the proven Microsoft Azure platform — trusted by healthcare companies, financial institutions and other companies worldwide with their sensitive data — to securely run simulations in the cloud. Azure consists of multiple defense layers, including strict protocols that prohibit unauthorized access to its facilities and leading-edge encryption methods to safeguard customer proprietary data.

Offering a user experience that is architected and optimized uniquely for ANSYS users, ANSYS Cloud allows engineers to model and develop their products faster than ever and expedite the path to market. 🚗

References

[1] HPCWire, Hyperion: Deep Learning, AI Helping Drive Healthy HPC Industry Growth. hpcwire.com/2017/06/20/hyperion-deep-learning-ai-helping-drive-healthy-hpc-industry-growth

[2] Gartner, Gartner Says 28 Percent of Spending in Key IT Segments Will Shift to the Cloud by 2022. gartner.com/en/newsroom/press-releases/2018-09-18-gartner-says-28-percent-of-spending-in-key-it-segments-will-shift-to-the-cloud-by-2022

[3] Cisco Systems, Cisco Global Cloud Index: Forecast and Methodology, 2016–2021 White Paper. cisco.com/c/en/us/solutions/collateral/service-provider/global-cloud-index-gci/white-paper-c11-738085.html

Developing the Next Generation of Automotive Engineers



Rob Harwood, ANSYS global industry director, met with professor Stefan-Alexander Schneider from the University of Applied Sciences at Kempton in Bavaria, Germany. Professor Schneider runs one of the world's only master's courses on advanced driver assistance systems and autonomous vehicles. Their conversation revealed how the University of Applied Sciences is helping to develop the disruptive technologies of tomorrow and the engineers who will deliver them. They also discussed why simulation is critical for autonomous vehicles.

A COURSE IS BORN

Rob Harwood: Professor Schneider, you run a unique master's class on autonomous driving at the university. Can you tell us more about how the course started and what it includes?

Stefan-Alexander Schneider: The idea started back in 2012 after the prime minister of Bavaria, Mr. Seehofer, visited Continental Automotive Distance Control

Systems GmbH Industrial Sensors (A.D.C.) in Lindau and was told that engineers with specific engineering skills — such as systems engineering and those related to the development of driver assistance systems and autonomous vehicles — were needed. So we established the master's course for advanced driver assistance systems in 2014. It was driven by the industry — companies like AVL, Bosch, BMW, Continental and AGCO. The goal is to educate more engineers in systems engineering related to driver assistance systems,



Stefan-Alexander Schneider

rather than just turning out more specialists in mechanical, electrical or computer engineering. All of these companies provided their requirements, and that information helped us to develop the curriculum, which balances mechanical engineering with vehicle dynamics, and includes test and development methods, like the famous V-model

in the automotive industry. It also includes sensor technology, like cameras and radars, microcontrollers, network protocols, and so on, as well as computer science for the algorithms needed, for example, to recognize patterns important for autonomous driving. We are really making great progress. We have projects that involve a number of companies. Using our knowledge, experience and material, we recently supported a master's course in connected automated vehicles in Sligo, Ireland, and we are also working closely with some universities in Japan. Our workshops like ROAD [roundtable on the purpose of autonomous driving] are very popular, and I'm really happy to be heading this master's course.

“The goal is to educate more engineers who have systems engineering knowledge related to driver assistance systems.”

RH: How many students are taking the course and how long does it take to graduate?

SAS: The course is three semesters: two for studies of six modules each and one for the master's thesis. We now have nine waves of students because you can start in the winter term or the summer term. Altogether that's around 120 students, which means about 12 or 13 students at each starting point.

RH: In addition to academic studies, you have also established some test facilities. Can you talk about how these facilities complement the academic work?

SAS: In Germany we have a two-layer educational system: universities and universities of applied science. The universities focus on longer-term developments, and we at the University of Applied Science focus on technology that has to be on the road in a couple of

years. Therefore, we work closely with companies all over the world. The students have already been to Japan, the U.S.A., Italy and France. This is important to show the strength of our collaboration with the industry. We have established a “Drive Living Lab” to understand the development tools, and the development and test methods, that are necessary in the automotive industry. We have a facility of 500 square meters where we have now started to perform research with companies and educate the students. In addition, the Bavarian state funded a research institute for advanced driver assistance systems and connected cars close to Kempton so that our research can be done adjacent to real cars.

RH: How does your location, relatively close to Munich, help?

SAS: All of the important German OEMs like Audi and BMW are close by and Continental A.D.C. is in nearby Lindau and Ulm. They also have a test facility in Memmingen. Both small and large companies are

nearby. Radar research and development for aircraft and cars has been centered in Ulm for a while. A number of established companies were already developing sensors that are now an important component of autonomous driving systems. In Germany, we would say we are like the middle of the spider's web.

RH: How did your passion for the automotive industry and for autonomous vehicles start?

SAS: I was always interested in cars. Recently I had a look at my old picture collection and I found a photo of myself driving an Opel when I was a small boy. I joined BMW in 2003 in a group focused on the development of embedded software and then changed my focus to the simulation of the full vehicle. I learned that system development needs simulation because it's not just a car, it's the interaction of the human and the machine. This brings all my passions together.

AUTONOMOUS VEHICLES: REAL OR HYPE?

RH: Autonomous vehicles — are they real or is it hype?

SAS: It is not hype although you might think that because there's so much interest from all levels of

society. Transportation is a basic need of humanity, and everywhere that transportation is involved, people are thinking about autonomy.

RH: The human benefits of autonomous vehicles are reducing accidents and congestion, and increasing mobility. What do you see as some of the business aspects for people who are creating autonomous vehicles?

SAS: Typically, there's a triangle of factors. Safety is imperative and is a prerequisite. The second part of the triangle is that transportation is what people pay for. Finally, you must also pay for comfort.

RH: Do you see any downside, any negatives, in the rise of the autonomous vehicle?

SAS: One major issue that must be resolved is security. Another is social acceptance. When looking at other transport systems, like an elevator or lift, years ago someone helped you to press the button to ensure correct operation. Today everyone is used to selecting the floor and doesn't give it a second thought. I think eventually this will occur with autonomous cars, even though we don't know how and when, but there's a strong political, social and economic push for it to happen.

RH: We see a lot of pressure to bring the technology to market. What do you see as the biggest barrier to overcome?

SAS: The safety aspect and the security aspect are two pictures of the same social acceptance challenge. You have to show that this new technology is at least as good as the old and has more upside than downside. Then, the hurdle will be to show confidence in these functionalities. We expect that this new technology will be safer, so there must not be any accidents in 12 million km (the average distance between fatalities on German motorways).

RH: That's a vast number. Are the automotive design processes as they stand today able to get us to the point of proving safety within a practical time frame?

SAS: If you look at the homologation process (proving the ability to satisfy regulatory standards and specifications), it is not possible to drive 12 million kilometers and demonstrate statistical significance. Even if you have one thousand prototypes, this is not

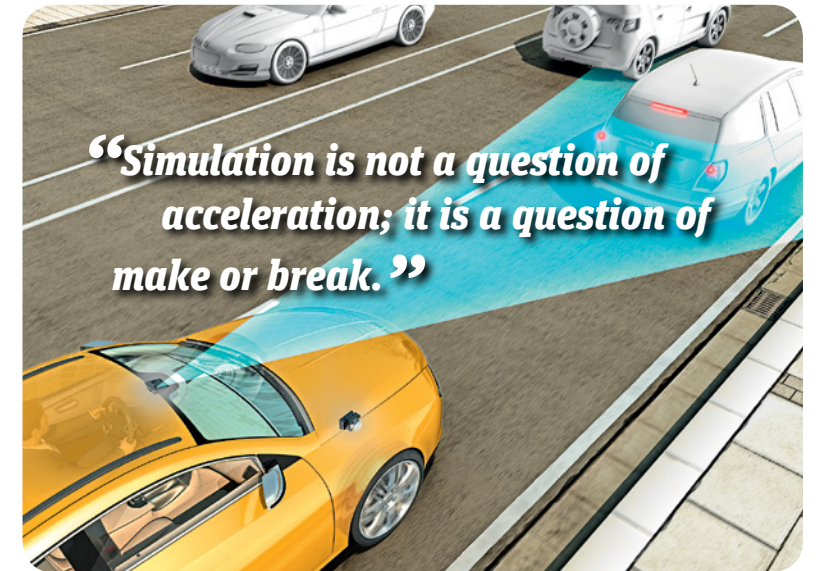

very likely. There's no way to do it through normal test activities, so test campaigns can be conducted using simulation methods. And this is one of the big benefits of simulation.

SIMULATION IS CRITICAL

RH: Simulation is the key to the practical delivery of safe autonomous vehicles. Can you explain a little bit more about the role of simulation?

SAS: Simulation is necessary to introduce short feedback loops in development, especially in the very beginning when you make basic decisions about design. It is important to get user experience or human-machine interaction feedback to understand the winning point of this function. Simulation no longer represents just the interaction between the vehicle and its environment, but all the important aspects (in abstract) of interaction between the vehicle, the environment and the driver. And the driver is not easy to understand. In a physical test of an autonomous vehicle on the motorway, full braking occurred and we did not understand why. When reviewing the camera videos, we saw that a caravan in the right lane had a bicycle mounted on the back and the algorithm detected this bicycle as though it was headed toward the car. The autonomous system said “stop” and braking occurred. This shows how humans when driving understand the context, and we must teach machines this contextual understanding. This is really challenging. At the moment, nobody knows which aspects of the environment are important and which can be neglected. Therefore, there's a strong need to understand this magic triangle of driver, vehicle and environment. Methods and simulation tools have to be able to support this.





RH: Simulation seems to span many aspects and include an ecosystem of tools. Is there a need for these tools to be open to interact with each other?

SAS: There is a strong need to have well-balanced modeling of all the different aspects. If you look at the landscape of tools, you will see that these tools are developed for specific use cases. For example, one tool is useful for the control code, and one tool is useful for special aspects of the vehicle models. If you want to benefit from these highly adaptive simulation tools, there needs to be a standardized interface to couple them. I think this will play an important role in the simulation of the driver, vehicle and environment.

RH: So how is the industry balancing functional safety and traceability with technologies like artificial intelligence and machine learning?

SAS: At the moment, this is really challenging because the homologation aspect is so important. Regulators will ask companies to explain how the algorithm works or what it will do, and this is very hard to determine. How to get out of this trap is a really interesting point of discussion. One idea is degradation and a regular understandable implementation of a code as a kind of watchdog, and you run an artificial intelligence code in parallel.

RH: Is this the Control-Monitor or Con-Mon approach?

SAS: Yes, a watchdog algorithm or something like that.

RH: It is clear that simulation is critical to the development of these vehicles in a practical time frame. Do you have a feel for the potential time savings provided by simulation?

SAS: Simulation is not a question of acceleration; it is a question of make or break. This is perhaps the first time in development that you cannot do without some aspects of simulation or simulation support.

TRADITIONAL OR HIGH-TECH?

RH: Many players are now trying to enter the autonomous vehicle market, including traditional OEMs and their suppliers, but we also see other companies from the high-tech and semiconductor industries. When the market settles down, who do you think will be the key players?

SAS: This is difficult to answer. If you look at the traditional OEMs, they have a lot of experience, in some cases more than 100 years, in developing, manufacturing and distributing cars, and they have a development network all over the world. But these companies can lose agility. And in autonomous driving we see strong companies — new kids on the block — come into the market, especially from information technology. IT is a basic ingredient for understanding the value chain and therefore the interplay of the driver and the environment. And they are making

great progress, but what they are missing is this network, the scalability, the industrialization. They make good prototypes, but they need to show that they can copy them in a way that a lot of people can benefit from. At the moment, we see a really interesting situation: All these companies are showing prototypes, both the old OEMs as well as the new companies. But they cannot make money with one prototype — they must copy this prototype a million times, so maybe joint ventures will

be the path to success. Right now no one can say; you would need a crystal ball.

RH: As someone who is passionate about the automotive industry and automobiles, do you think you will ever be driven by an autonomous vehicle?

SAS: I will be the first! Yes, I like that, and it's amazing and overwhelming.

RH: And do you think one of your students will be the producer of the car that drives you around?

SAS: We have already had a running autonomous car on our facility, so yes, I think they are also passionate to drive and to be driven. Fueled to be driven! 🚗

References

University of Applied Science, Kempten, hochschule-kempten.de (06/12/18)
 Institute of Technology Sligo, itsligo.ie/courses/meng-connected-autonomous-vehicles/ (06/12/18)

“Transportation is a basic need of humanity, and everywhere that transportation is involved, people are thinking about autonomy.”

Simulation in the News

ANSYS 2019 R2 STRENGTHENS DIGITAL THREAD CONNECTING DESIGN, ENGINEERING AND MANUFACTURING

DEVELOP3D, JUNE 2019

Digital transformation is impacting every industry. Through groundbreaking digital technologies, hardware and software developers can work together in all phases of the product development cycle and shave years off their product timelines. With new functionalities in ANSYS 2019 R2, including new materials capabilities for structural analysis following the recent acquisition of Granta, ANSYS simulation solutions accelerate collaboration, validation and verification — creating a reliable digital thread connecting all operations.

The latest ANSYS release accelerates digital transformation across every industry. Improvements have been made across all product areas.

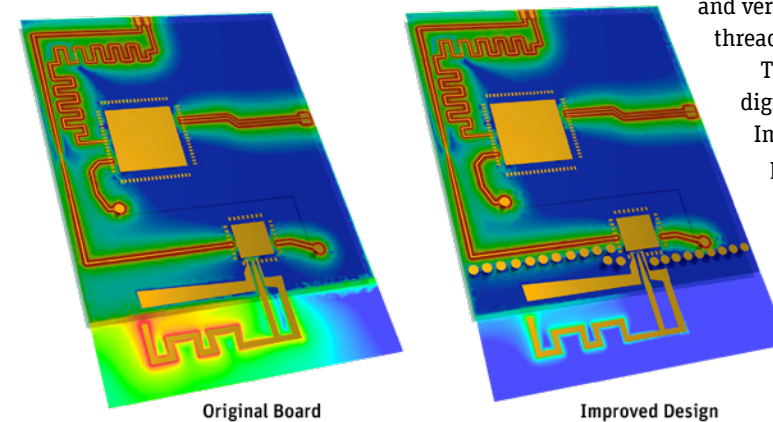

The latest release of ANSYS electromagnetics simulation tools focuses on improvements and new simulation capabilities that help engineers design products for 5G, autonomous and electrification technologies.



ANSYS VRXPERIENCE continues to lead the autonomous revolution with new features for development, virtual testing and validation of systems. With the new physics-based GPU rendering, you can explore an interactive version of your SPEOS simulation model and obtain immediate results directly.

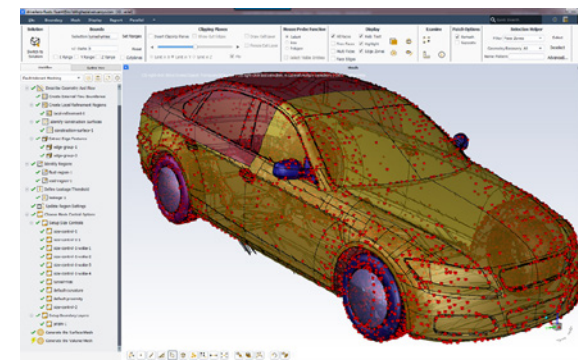

ANSYS Fluent's new fault-tolerant workflow simplifies CFD analysis of non-watertight CAD models. Geometry courtesy of Technical University of Munich (TUM)

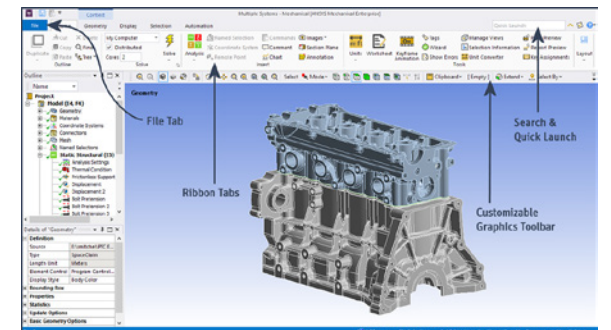

ANSYS 2019 R2 introduces a new user interface for ANSYS Mechanical. This will improve productivity and simplify customization.

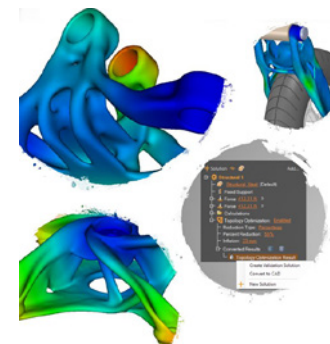

ANSYS Discovery Live streamlines and expands the range of applications for conceptual design and real-time simulation. In the ANSYS 2019 R2 release, Discovery Live can resurface topology-optimized geometry and convert it into surface-based computer-aided design (CAD) geometry for use in downstream tools.



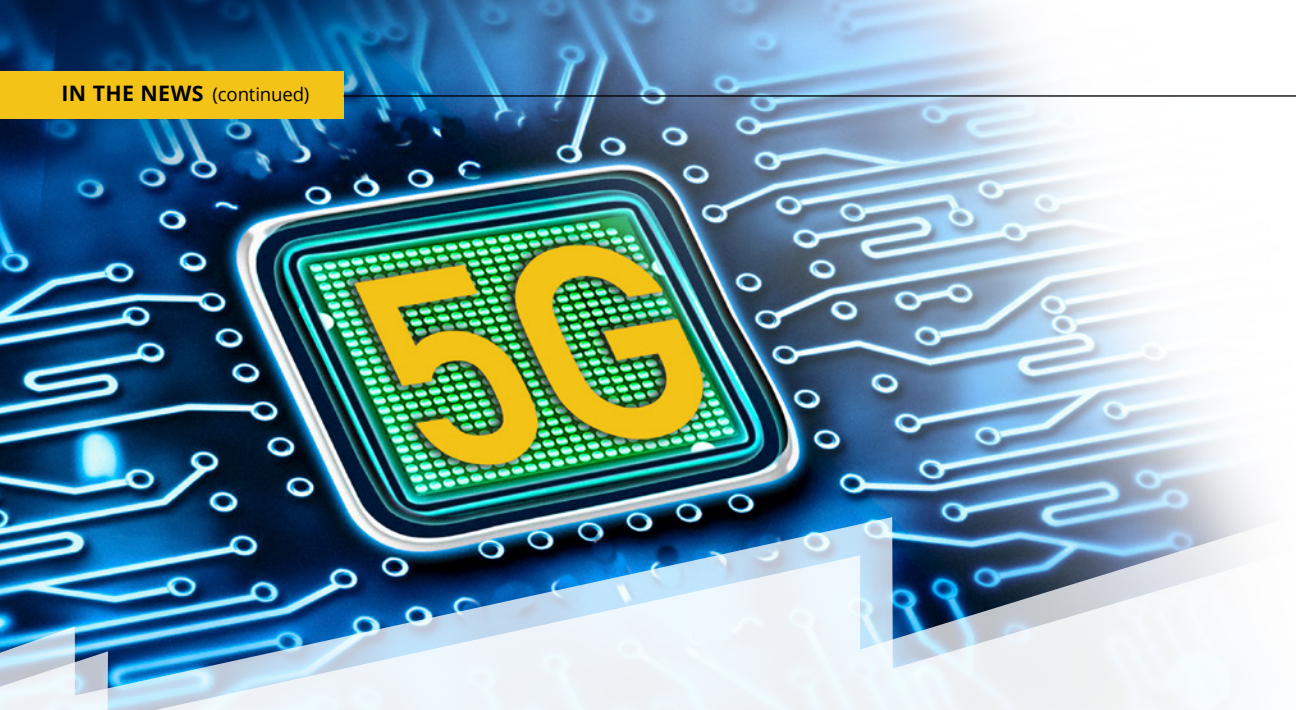

ESILICON REVOLUTIONIZES NEXT-GENERATION SYSTEM-IN-PACKAGE DESIGNS

StreetInsider.com, May 2019

eSilicon is pioneering complex system-in-package designs with significantly increased speed, efficiency and production-proven accuracy thanks to ANSYS. eSilicon leverages ANSYS' industry-leading multiphysics simulation solutions to ensure silicon-to-system success — accelerating time-to-market for its high-bandwidth networking, high-performance computing, artificial intelligence (AI) and 5G infrastructure customers.



70% OF CONSUMERS EXPECT TO TRAVEL IN AN AUTONOMOUS AIRCRAFT IN THEIR LIFETIME

CNBC, June 2019

While 70% of consumers are ready to fly in an autonomous plane in their lifetime, only 58% are willing to board a self-flying plane in the next decade. Twelve percent insist on waiting longer than 10 years. Respondents said they are most concerned with technology failure (65%) and autopilot response to external conditions, such as bad weather and turbulence.

Timeline for Adoption:

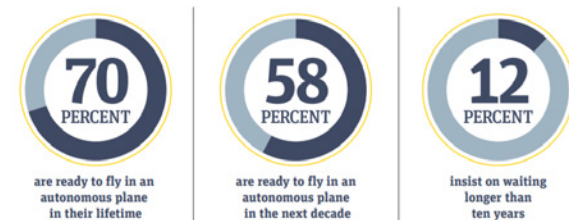

ANSYS AND BMW GROUP PARTNER TO JOINTLY CREATE THE INDUSTRY'S FIRST SIMULATION TOOL CHAIN FOR AUTONOMOUS DRIVING

HPCwire, June 2019

The simulation tool chain will enable highly automated and autonomous driving. The multi-year agreement drives the development of BMW Group's Level 3 offering and Level 4-5 technology, delivering high/full automation for the highly anticipated BMW iNEXT, expected to launch in 2021.

RFS AND ANSYS LAY FOUNDATION FOR 5G-READY ANTENNAS

Digital Engineering 247, May 2019

Cutting-edge 5G antennas pioneered by Radio Frequency Systems (RFS) will soon connect people, machines and devices more reliably and faster than ever thanks to ANSYS. Standardizing on ANSYS simulation solutions enables RFS engineers to slash simulation time from four days to one hour — speeding their antennas to market and driving global adoption of 5G.

VOLKSWAGEN SMASHES TIME RECORD AT LEGENDARY NÜRBURGRING

Automotive Testing Technology International, May 2019

Volkswagen Motorsport's ID.R race car, powered by ANSYS simulation solutions, cemented its place in racing history by shattering the lap time record for electric vehicles at the Nürburgring Nordschleife. Finishing in 6.05.336 minutes, Volkswagen driver Romain Dumas pushed the ID.R's battery — supported by ANSYS simulations — to its limits on the demanding German race track, showcasing its industry-leading electrical efficiency.



ANALYTICAL GRAPHICS AND ANSYS LAUNCH JOINT TECHNOLOGY PARTNERSHIP

ExecutiveBiz, May 2019

This strategic agreement leverages physics-based models to deliver mission simulations with unparalleled accuracy and reliability. AGI expects to enable satellite, aerospace and defense customers to create more precise and reliable modeling and mission simulations with greater accuracy for complex scenarios, including aircraft missions through contested airspace and satellites orbiting the Earth.

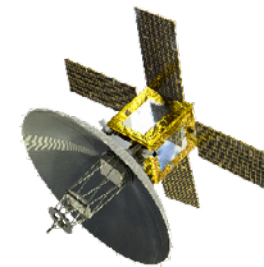

ANSYS SOLUTIONS CERTIFIED FOR SAMSUNG 5LPE PROCESS TECHNOLOGY

ansys.com, May 2019

ANSYS multiphysics solutions are enabled on Samsung's latest FinFET technology.

ANSYS ACQUIRES ASSETS OF DFR SOLUTIONS

Pittsburgh Business Times, May 2019

This acquisition gives customers access to Sherlock, the industry's only automated design reliability analysis software. When combined with ANSYS' solutions, customers will be able to quickly and easily analyze for electronics failure earlier in the design cycle.

ANSYS ANNOUNCES INDIAN INSTITUTE OF TECHNOLOGY BOMBAY PH.D. FELLOWSHIP PROGRAM

APN News, April 2019

ANSYS and the Indian Institute of Technology Bombay will accelerate groundbreaking research across healthcare and conservation industries through a newly launched Ph.D. fellowship program funded by ANSYS.

CERTIFICATION FOR INNOVATIVE SYSTEM-ON-INTEGRATED-CHIPS STACKING TECHNOLOGY

ansys.com, April 2019

TSMC and ANSYS enable 3D-IC reference flows for mutual customers to address multiphysics challenges.

ANSYS RECOGNIZED AS A LEADER IN CORPORATE SUSTAINABILITY

CIMdata, February 2019

Corporate Knights, a media and research company dedicated to promoting corporate sustainability, named ANSYS to its 2019 global 100 Most Sustainable Corporations in the World index (Global 100). ANSYS simulation enables engineers around the globe to create a more sustainable world.

